

Sabre Disc Drive

ST81154K DKO-502

ST81236K DKO-501

User's Manual

(IPI Interface)

 **Seagate**

WARNING

Do not attempt to install, operate, or repair the unit, before you read the important safety information located directly after the table of contents in this manual. Failure to follow that and other safety precautions in this manual could cause injury to yourself or others.

WARNING

This equipment generates, uses and can radiate radio frequency energy and if not installed and used in accordance with the instructions manual, may cause interference to radio communications. It has been tested and found to comply with the limits for a Class A computing device pursuant to Subpart J of Part 15 of the FCC Rules which are designed to provide reasonable protection against such interference when operated in a commercial environment. Operation of this equipment in a residential area is likely to cause interference in which case the user, at his own expense, will be required to take whatever measures may be required to correct the interference.

If the operator or status/control panel (component assembly) is not installed in the inner drawer, it is your responsibility to provide any additional RFI shielding or grounding needed to ensure FCC Class A compliance.

Sabre Disc Drive

**ST81154K (97229-11G)
ST81236K (97209-12G)**

User's Manual (IPI Interface)

**About the Disc Drive
Installing the Disc Drive
Operating the Disc Drive
Testing the Disc Drive**

Publication Number: 83326010-E



REVISION RECORD

REVISION	DESCRIPTION
A (11-01-87)	Manual Released.
B (05-31-88)	Manual revised. This revision includes information about the sweep cycle feature, incorporates a new control board, and includes miscellaneous technical changes.
C (11-23-88)	Manual revised. This revision includes information about the PA8Y2, two-head parallel drives. This edition obsoletes all previous editions.
D (08-09-89)	Manual revised. This revision includes information about the air baffle and spindle synchronization and includes miscellaneous technical changes. This edition obsoletes all previous editions.
E (02-22-90)	Manual revised to incorporate new control board and I/O board information, and also various technical and editorial changes. This edition obsoletes all previous editions.

REVISION LETTERS I, O, Q AND X ARE NOT USED.

Copyright Notice

Seagate, Seagate Technology, and the Seagate logo are registered trademarks of Seagate Technology, Inc. This publication is copyrighted with all rights reserved and may not be copied, in whole or in part, without written permission of Seagate Technology, Inc.

Seagate reserves the right to change product offerings or specifications without notice.

© 1988, 88, 89, 90
By Seagate Technology, Inc.
Technical Publications Department
12701 Whitewater Drive
Minnetonka, MN 55343

We value your comments. A Comment Sheet is provided at the back of this manual.

Printed in the United States of America

IMPORTANT SAFETY INFORMATION AND PRECAUTIONS

Use of proper safety and repair techniques is important for safe, reliable operation of this unit. Service should be done only by qualified persons. We recommend the procedures in this manual as effective ways of servicing the unit. Some procedures require the use of special tools. For proper maintenance and safety, you must use these tools as recommended.

The procedures in this manual and labels on the unit contain warnings and cautions that must be carefully read and followed to minimize or eliminate the risk of personal injury. The warnings point out conditions or practices that may endanger you or others. The cautions point out conditions or practices that may damage the unit, possibly making it unsafe for use.

You must also understand that these warnings and cautions are not exhaustive. We cannot possibly know, evaluate, and advise you of all the ways in which maintenance might be performed or the possible risk of each technique. Consequently, we have not completed any such broad evaluation. If you use a non-approved procedure or tool, first ensure that the method you choose will not risk either your safety or unit performance.

For the safety of yourself and others, observe the following warnings and precautions.

- Perform all maintenance by following the procedures in this manual.
- Follow all cautions and warnings in the procedures and on unit labels.
- Use the special tools called out in the procedures.
- Use sound safety practices when operating or repairing the unit.
- Use caution when troubleshooting a unit that has voltages present. Remove power from unit before servicing or replacing parts.
- Wear safety glasses when servicing units.
- Wear safety shoes when removing or replacing heavy parts.
- Use only designated Seagate replacement parts. Non-Seagate replacement parts can adversely affect safety in addition to degrading reliability, increasing maintenance downtime, and voiding warranty coverage.

- Use care while working with the power supply because line voltages are always present when the ac power cord is connected to a power source. Setting the power supply switch to position "⏻" disables dc power to the drive but has no effect on ac power within the supply. For complete safety, remove the ac power plug from the site power outlet.
- The site power outlet shall be installed near the equipment and shall be easily accessible.
- In case of fire or other emergency, isolate the drive from main power by removing the drive power plug from the ac outlet. In situations where pulling the plug is not possible or practical, use the system main power disconnect to isolate the drives from main power.
- In an IT power system, a disconnect device shall be provided which simultaneously interrupts all phase and neutral conductors.
- When the drive is mounted in an equipment rack or cabinet, ensure that the internal temperature of the rack or cabinet will not exceed the limits defined for the drive. Where units are stacked vertically, pay special attention to the top where temperatures are usually highest.
- This drive is designed to be installed and operated in accordance with UL1950, IEC380, IEC950, EN 60950, CSA C22.2 154, CSA C22.2 220, and VDE0806.
- Follow the precautions listed under Protecting the Drive From Electrostatic Discharge.
- If the power supply is placed on a bench for testing, position the supply so all ventilation holes are open, to allow proper air flow to internal components.
- Do not attempt to disassemble the module. It is not field repairable. Replace the entire module assembly if it is defective.
- Do not operate the drive over an extended period of time without the top cover installed.
- The power supply is designed to be connected to an IT network.

- Do not attempt to disassemble the power supply. It is not field repairable. Replace the entire supply if it is defective.
- If you do not use a recommended Seagate power supply, ensure the supply meets the specifications in this manual and is designed to be used in accordance with UL1950, IEC380, IEC950, EN 60950, CSA C22.2 154, CSA C22.2 220, and VDE0806.

CONTENTS

Important Safety Information and Precautions	f-3
Equipment Configuration Chart	f-19
Abbreviations	f-21
SECTION 1. ABOUT THE DISC DRIVE	
About the Disc Drive	1-1
About the Intelligent Peripheral Interface (IPI)	1-1
A Complete Drive	1-2
The Power Supply	1-2
I/O Cables	1-3
Spindle Sync Cable	1-3
The Top Cover	1-4
The Rear Panel	1-4
The Module	1-5
Circuit Boards	1-6
Cooling Provisions	1-7
Operator Panel	1-8
Status/Control Panel	1-8
How The Drive Writes and Reads	1-9
Two-Head Parallel Drives	1-12
Bit Interleave Mode	1-12
Byte Interleave Mode	1-13
Word Interleave Mode	1-13
One-Head Mode	1-13
Drive Specifications	1-14

SECTION 2. INSTALLING THE DISC DRIVE	
Things to Consider Before You Begin Installing the Drive	2-1
The Installation Process	2-1
Protecting the Drive from Electrostatic Discharge	2-2
Accessories	2-3
Space Requirements	2-4
Heating and Cooling Requirements	2-5
Electrical Requirements	2-7
Interface Requirements	2-9
Star I/O Cabling	2-10
Daisy Chain I/O Cabling	2-10
I/O Cable Pin Assignments	2-11
The Spindle Sync Feature	2-12
The Spindle Sync Cable	2-12
Unpacking the Drive	2-13
Inspecting the Drive	2-14
Packing the Drive	2-14
How to Check the Power Supply Voltage Selection	2-15
How To Change the Power Supply Voltage Selection	2-15
Installing the 2X Drawer In a Rack	2-16
Installing the Operator Panel or Status/Control Panel Jumper Cable	2-18
Installing the Power Supply in the Inner Drawer	2-19
Installing the Drive in the Inner Drawer	2-20
Installing the Inner Drawer into the 2X Drawer	2-21
Installing the Front Panel	2-22
Installing the Status/Control Panel	2-23
Installing the Operator Panel	2-24
Other Ways to Mount the Drive	2-25
Connecting Star System I/O Cables	2-27
Connecting Daisy Chain System I/O Cables	2-28
Spindle Sync Cable Connections	2-29

Connecting a Star System Ground	2-30
Connecting a Daisy Chain System Ground	2-31
Providing a Safety Ground	2-32
How to Operate DIP Switches	2-33
Setting the I/O Board Switches	2-34
Spindle Synchronization Information	2-37
The Enable Master Sync Switch (or Jumper)	2-37
How to Access the Enable Master Sync Jumper	2-38
Designating a Master Using the Enable Master Sync Switch	2-39
Designating a Master Using the Enable Master Sync Jumper	2-39
Designating A Master Using Bus Controls	2-39
Setting the Control Board Switches	2-40
Control Board Indicators	2-42
Setting the Control Board Jumpers	2-43
Sweep Cycle Information	2-45
Which Drives Have the Sweep Cycle Feature	2-45
How to Enable or Disable the Sweep Cycle Feature	2-46
How the Sweep Cycle Works	2-46
Checking Local Mode Operation	2-47
Checking Remote Mode Operation	2-49
Adding an Operator Panel or Status/Control Panel	2-51

SECTION 3. OPERATING THE DISC DRIVE

Getting Acquainted With the Drive	3-1
The Address Indicators	3-1
The ADDRESS Switch	3-2
The SEL (Selected) Indicator	3-2
The Ready Indicator	3-2
The START Switch	3-3
The FAULT Indicator	3-3
The Fault Clear Switch	3-4
The WRITE PROTECT Indicator	3-4
The WRITE PROTECT Switch	3-4

The Power Supply On/Standby Switch	3-5
How to Start a Drive with no Operator Panel	3-6
How to Start a Drive with the Optional Operator Panel	3-7
How to Stop the Drive	3-8
Stopping the Drive Using the Optional Operator Panel	3-8
Stopping the Drive Using the Power Supply On/Standby Switch	3-8
Using the Spin Up/Spin Down Function	3-9
Dual Port Failures	3-9
How to Replace the Air Filter	3-9

SECTION 4. TESTING THE DISC DRIVE

About Testing the Drive	4-1
Drive Power On Tests	4-2
Drive Self-Test Failure Indications	4-3
About the Offline Diagnostic Tests	4-4
How to Select and Run Diagnostic Tests	4-5
Test 00 -- Display Drive Operating Status Log	4-6
Test 01 -- Display Fault Log	4-7
Test 04 -- Calculate Three Most Likely Field Replaceable Units	4-9
Test 05 -- Servo Test	4-10
Test 06 -- Clear Drive Operating Status Log	4-11
Test 07 -- Clear Fault Log	4-12
Test 08 -- Direct or Continuous Seeks	4-13
Test 09 -- Random Seek	4-15
Test 0C -- Display EPROM Part Number	4-16
Test 0E -- Return To Zero	4-16
Drive Status Codes	4-17
Interface Testing	4-22
The Self-Test and Initialization Sequence	4-22
Starting the Tests	4-23
Execute Internal Diagnostics Function	4-24

Read Drive Specific Information (Bus Control 43)	4-24
Native-Controlled Diagnostic Status Codes	4-26
Native-Controlled Diagnostic FRU Codes	4-27
Native-Controlled Diagnostic Fault Codes	4-27
Interface-Controlled Diagnostic Status Codes	4-28
Interface-Controlled Diagnostic FRU Codes	4-29
Interface-Controlled Diagnostic Fault Codes	4-29
A. INSTALLATION AND OPERATING REQUIREMENTS (GERMAN)	
B. INSTALLATION AND OPERATING REQUIREMENTS (FRENCH)	
C. INSTALLATION AND OPERATING REQUIREMENTS (SPANISH)	

FOREWORD

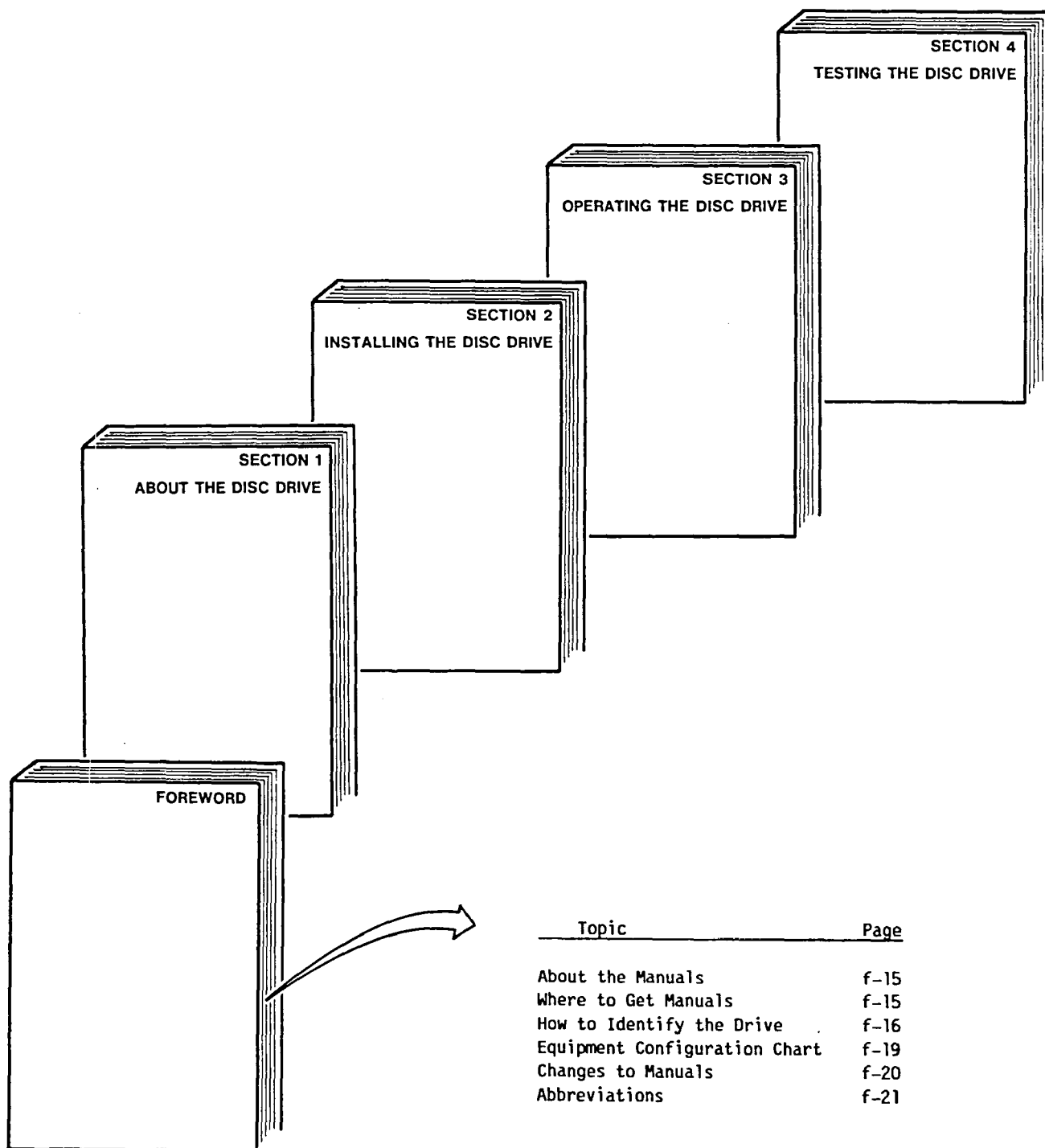

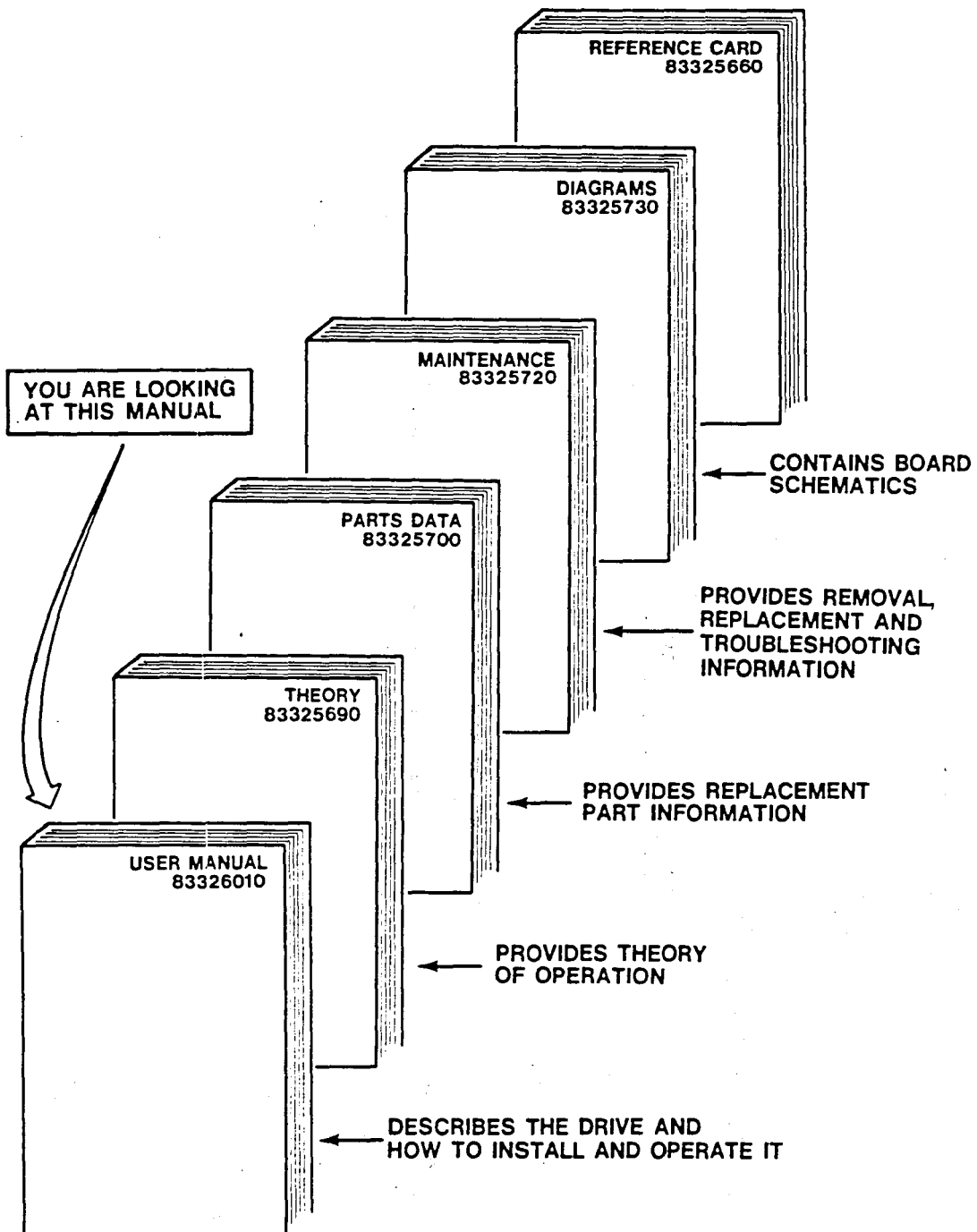

11F367

ABOUT THIS MANUAL

This manual is for you, the user of the PA8xx SABRE eight-inch module drive. This manual describes the drive and how to install and operate it. Diagnostic testing and status information is also provided.

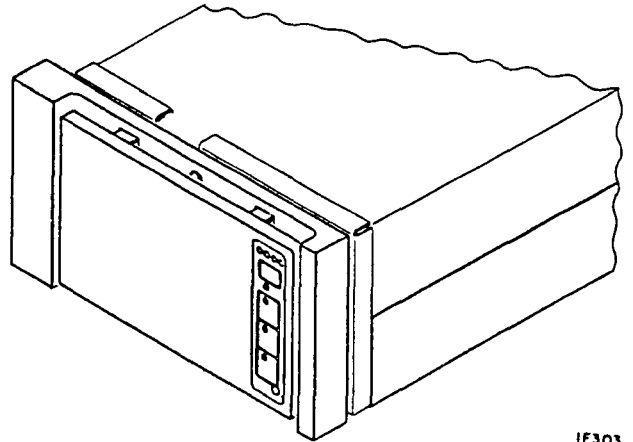

IF303

ABOUT THE OTHER SABRE MANUALS

The other manuals in the set of manuals for this disc drive provide theory of operation, diagrams (board schematics), parts data, and maintenance information. Some of these manuals pertain to more than one model.

WHERE TO GET MANUALS

Additional copies of this manual or any of the other SABRE manuals can be obtained at the address shown.

Seagate Technology, Inc.
Customer Services
12701 Whitewater Drive
Minnetonka, MN 55343

Phone: (612) 931-8612
Fax: (612) 931-8817

HOW TO IDENTIFY YOUR DRIVE

You may need to identify the exact characteristics of your drive at some time in the future. The various equipment identification labels and the equipment configuration log help you and service persons identify your drive and its exact characteristics.

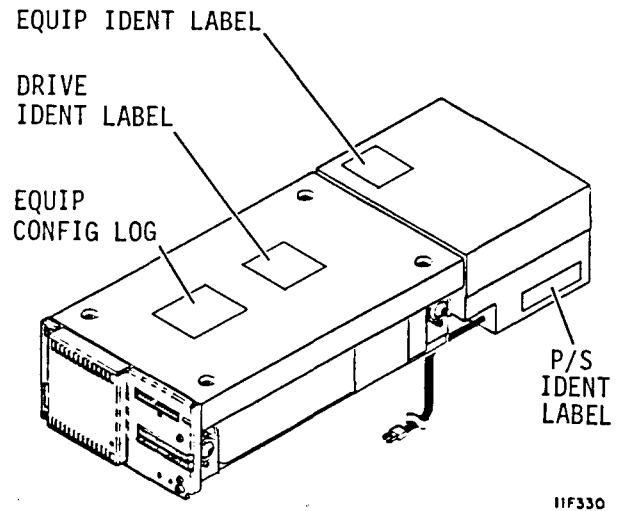

DRIVE IDENTIFICATION LABEL

The equipment identification label on the top cover of the drive identifies the physical and logical characteristics of the drive at the time it was manufactured.

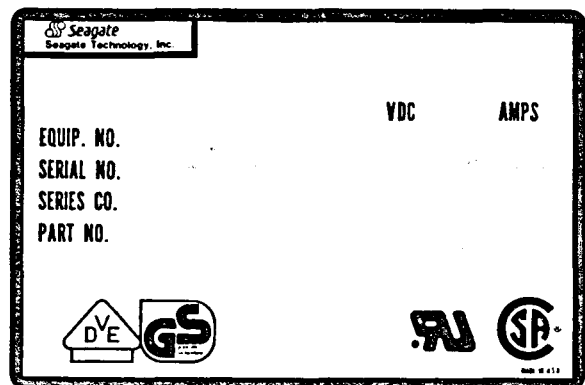

IIF328B

EQUIPMENT NUMBER

The equipment number has two parts. The equipment and type identifiers show the drive family and its basic functional characteristics. Refer to the Equipment Configuration Chart in this section for a listing of equipment numbers.

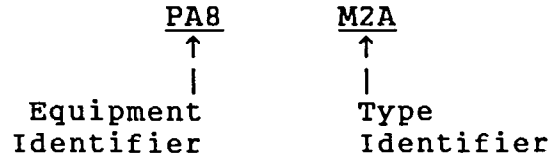

SERIES CODE

All drives interchange at the system level regardless of series code. Part differences exist in drives with different series codes. The series code helps identify your drive for parts ordering purposes.

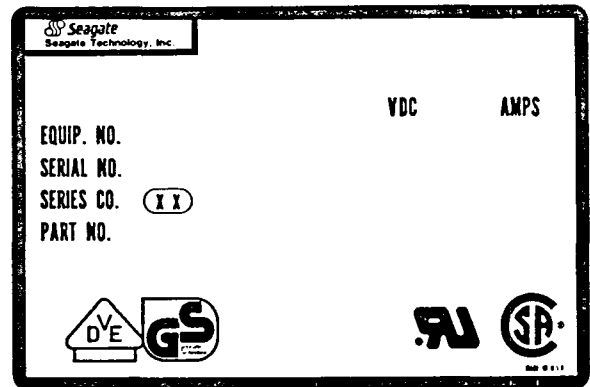

11F331B

SERIAL NUMBER

Each drive is assigned a serial number. Serial numbers are assigned sequentially within a family of drives. No two drives have the same serial number.

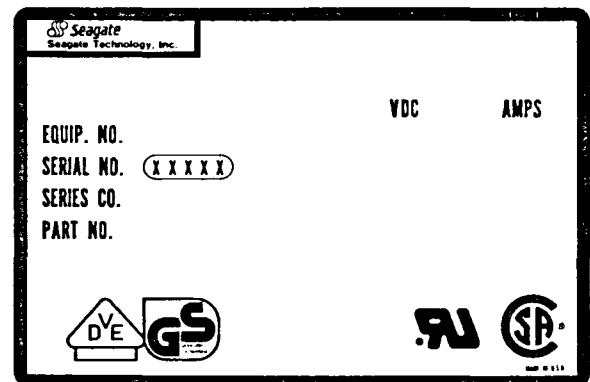

11F332B

POWER SUPPLY IDENTIFICATION LABEL

The label on the power supply identifies the parts that make up the drive installation. It also shows power information for the power supply.

Seagate Seagate Technology, Inc.		POWER SUPPLY			
		PART NUMBER	SERIAL NUMBER		
V \sim	Hz	Ph	A/Ph	WATTS	WIRE - GROUND
		▲		COMPONENT TYPE CUSTOM RECEIVED	
.RJ				SP	

11F329B

PART NUMBERS

An equipment package part number is assigned to the entire unit -- including the drive, power supply and, if applicable, any painted panels, installation hardware etc.

The complete drive assembly (CDA) is the number assigned to the drive only.

The power supply assembly number is the number assigned to the power supply only.

Seagate Seagate Technology, Inc.		PART NO. CONSISTS OF CDA NO. AND POWER SUPPLY			
V \sim	Hz	Ph	A/Ph	WATTS	WIRE - GROUND
DVE		GS		.RJ SP	

11F333B

DOES YOUR MANUAL MATCH THE DRIVE?

Changes made to the drive, whether made at the factory or by a service person after it is installed, cause changes in the manuals.

Your manual matches the drive if the field change orders (FCOs) and engineering change orders (ECOs) listed on the equipment configuration log are shown either on the revision record at the front of this manual or on the first sheet of a revision packet(s) supplied with it.

EQUIPMENT CONFIGURATION LOG

This log shows the changes that were made to the drive during its life cycle. The entries on this log may have been made in manufacturing or by service persons. They help track the history of the drive for service purposes. It is important that this log be kept current by persons who install any changes.

		EQUIPMENT CONFIGURATION LOG	
Seagate Technology, Inc.		PAGE NO. ____ OF ____	
BASE EQUIP. ID NO. _____		S/N _____	
INSTALLED OPTIONS			
EQUIPMENT ID NO.	SERIAL NO.	EQUIPMENT ID NO.	SERIAL NO.
* KEY FOR CHANGE NO. PREFIXES: F=FCO E=ECC D=DA(DEVIAION)			
FIELD HISTORY			
EQUIPMENT ID NO.	SERIAL NO.	*CHANGE NO.	DATE & INST. BY

11F334B

EQUIPMENT CONFIGURATION CHART

The equipment configuration chart below identifies each version of the equipment covered by this manual.

Equipment Number	Interface Type	Other Characteristics
PA8M2A	IPI	850 MB, Std Format
PA8M2B	IPI	850 MB, 512 Byte Format
PA8M2C	IPI	850 MB, 1024 Byte Format
PA8R2A	IPI	1230 MB, Standard Format
PA8R2B	IPI	1230 MB, 512 Byte Format
PA8R2C	IPI	1230 MB, 1024 Byte Format
PA8R2D	IPI	1230 MB, 288 Byte Format
PA8R2E	IPI	1230 MB, 2308 Byte Format
PA8Y2A	IPI	1153 MB, Two-Head Parallel

CHANGES TO THIS MANUAL

A List Of Effective Pages is provided at the back of this manual. It lists each page in the manual and its revision level. If you receive a manual and one or more packets of revised pages, each of the packets also contains a new List Of Effective Pages.

Instructions for inserting the revised pages into the manual are provided with each packet. If you have more than one packet to insert, always start with the least current and work toward the latest revision.

HOW CHANGES ARE INDICATED

New features, technical changes, additions, and deletions in this manual are indicated in three ways:

- A vertical bar in the outer margin of a page marks a changed area.
- A dot by the page number indicates the entire page contains new or changed information.
- A vertical bar by the page number indicates the information was moved from another page, but there were no technical or editorial changes.

ABBREVIATIONS

A	Ampere	CDA	Complete Drive Assembly
ABV	Above	CH	Channel
ac	Alternating Current	CHK	Check
ACK	Acknowledge	CLK	Clock
ADD	Address	CLR	Clear
ADDR	Address	cm	Centimetre
ADJ	Adjust	CNTR	Counter
ADRS	Address	COMP	Comparator
AGC	Automatic Gain Control	CONT	Control
ALT	Alternate	CONTD	Continued
AM	Address Mark	CT	Center Tap
AME	Address Mark Enable	CYL	Cylinder
AMP	Amplifier, Ampere	D/A	Digital to Analog
ASSY	Assembly	dc	Direct Current
ATN	Attention	DB	Data Bit
BLW	Below	DET	Detect
BSY	Busy	DIV	Division
C	Celsius	DLY	Delay
CB	Circuit Breaker		

ABBREVIATIONS (Contd)

DRVR	Driver	FTU	Field Test Unit
ECL	Emitter Coupled Logic	FWD	Forward
ECO	Engineering Change Order	GND	Ground
EMC	Electromagnetic Compatibility	HD	Head
EMD	Eight-Inch Module Drive	HEX	Hexagon
EN	Enable	Hg	Mercury
ENBL	Enable	HR	High Resolution
EPROM	Erasable Programmable Read Only Memory	HYST	Hysteresis
ESD	Electrostatic Discharge	Hz	Hertz
EXT	External	IC	Integrated Circuit
F	Fahrenheit, Fuse	ID	Identification
FCO	Field Change Order	IDENT	Identification
FDBK	Feedback	in	Inch
FIG	Figure	IND	Index
FLT	Fault	INTRPT	Interrupt
FRU	Field Replaceable Unit	I/O	Input/Output
ft	Foot	IPB	Illustrated Parts Breakdown
		IPS	Inches per Second

ABBREVIATIONS (Contd)

kg	Kilogram	NC	No Connection
kPa	Kilopascal	NORM	Normal
kW	Kilowatt	NRZ	Non Return to Zero
lb	Pound	ns	Nanosecond
LCD	Liquid Crystal Display	OC	On Cylinder
LED	Light Emitting Diode	OS	One-Shot
LSI	Large Scale Integration	OSC	Oscillator
LTD	Lock to Data	P	Plug
m	Metre	PD	Peak Detect
MAX	Maximum	pF	Picofarad
MB	Megabyte	PG	Page
MEM	Memory	PHH	Phillips Head
MHz	Megahertz	PLO	Phase Lock Oscillator
mm	Millimetre	PROC	Procedure
MPU	Microprocessor Unit	PROG	Programmable
MRK	Mark	PS	Power Supply
ms	Millisecond	PWR	Power
MSG	Message	RCVR	Receiver
MTR	Motor	RD	Read
mV	Millivolt	RDY	Ready

ABBREVIATIONS (Contd)

REF	Reference	TSP	Troubleshooting Procedure
REQ	Request	TTL	Transistor-Transistor Logic
RES	Resolution	V	Volts, Voltage
REV	Reverse, Revision	V _{bb}	Bias Voltage
RGTR	Register	VCC	Bias Voltage
r/min	Revolutions Per Minute	VCO	Voltage Controlled Oscillator
RST	Reset	W	Watts
RTZ	Return to Zero	W/	With
R/W	Read/Write	W/O	Without
s	Second	W PROT	Write Protect
S/C	Series Code	W+R	Write or Read
SEC	Second	W·R	Write and Read
SEL	Select	WRT	Write
SEQ	Sequence	XFR	Transfer
SPD	Speed	Ω	Ohms
SS	Sector Switch	\$	Hexadecimal Address
T	Tracks to go	uF	Microfarad
TF	Thread Forming	us	Microsecond
TIM	Timer		
TP	Test Point		

SECTION 1.

ABOUT THE DISC DRIVE

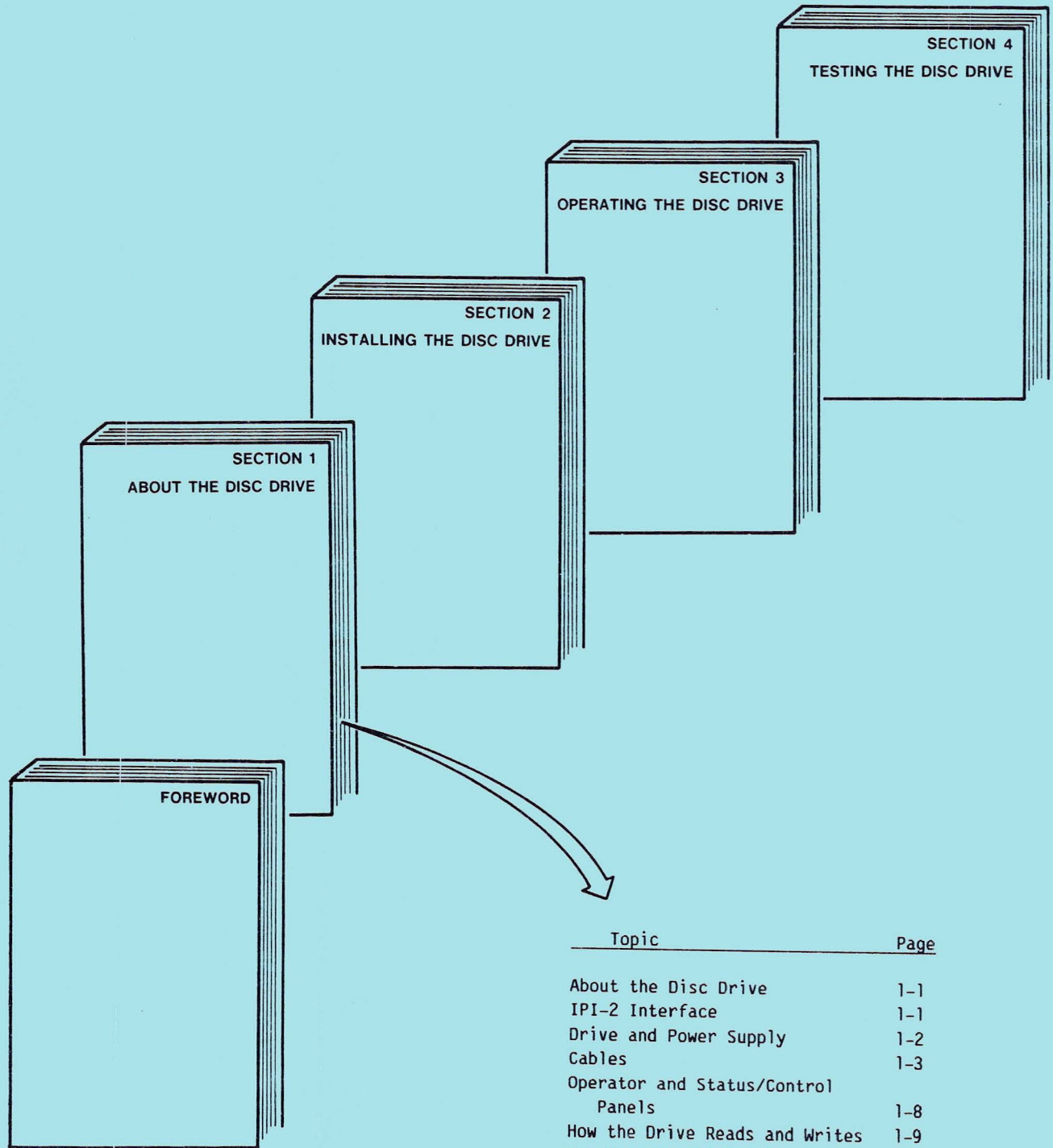

Topic	Page
About the Disc Drive	1-1
IPI-2 Interface	1-1
Drive and Power Supply	1-2
Cables	1-3
Operator and Status/Control Panels	1-8
How the Drive Reads and Writes	1-9
Two-Head Parallel Drives	1-12
Drive Specifications	1-14

ABOUT THE DISC DRIVE

The SABRE is a high-speed, eight-inch module, random access disc drive. The front panel shown is used when two drives are mounted beside each other in the optional 2X (two drives side-by-side) drawer. The 2X drawer can be mounted in a standard 19-inch rack, or the drive can be mounted in a custom cabinet or enclosure.

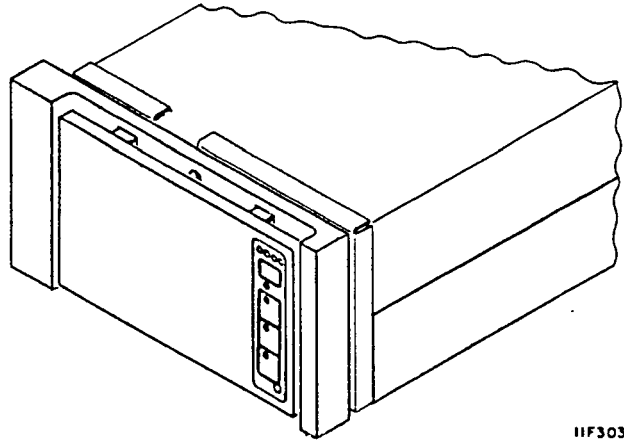

IIF303

ABOUT THE INTELLIGENT PERIPHERAL INTERFACE (IPI)

The drive communicates with the host using the Intelligent Peripheral Interface (IPI) and protocol. The signals on the interface cables are listed in Section 2 of this manual. The IPI signals and protocol are described in detail in the Theory manual. A dual port configuration is illustrated.

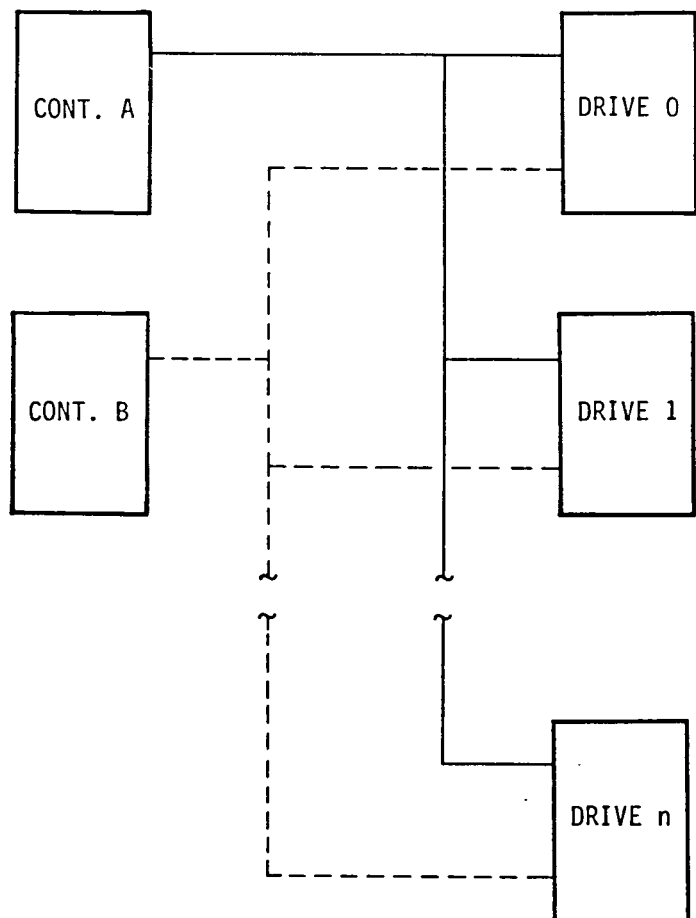

A COMPLETE DRIVE

As a minimum, installation of a single drive requires the following:

- the drive,
- a power supply,
- I/O cables,
- I/O terminator

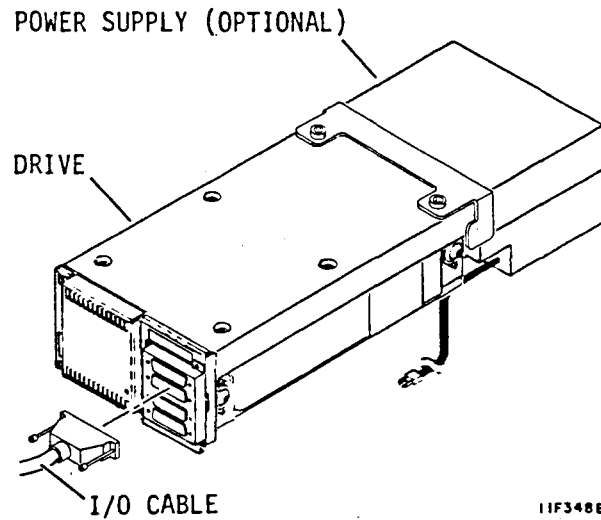

THE POWER SUPPLY

Site power enters the optional power supply through the ac power cable. The power supply provides the dc voltages needed to operate the drive. These voltages reach the drive through the dc power cable.

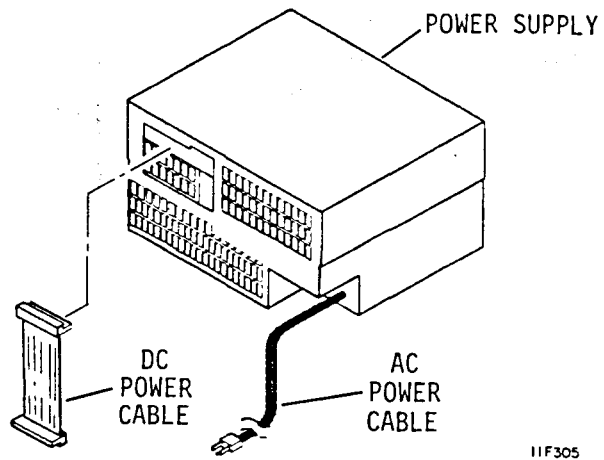

I/O CABLES

One shielded, 50-conductor (25 twisted-pair), I/O cable is needed for each port. Using shielded I/O cables permits meeting FCC/VDE requirements. Using shielded cables also minimizes signal cross-talk and inductive coupling.

The I/O cables have a male connector on one end and a female connector on the other. This allows joining of cables if you must remove a drive from a daisy chain. The controller must have a female connector for each port.

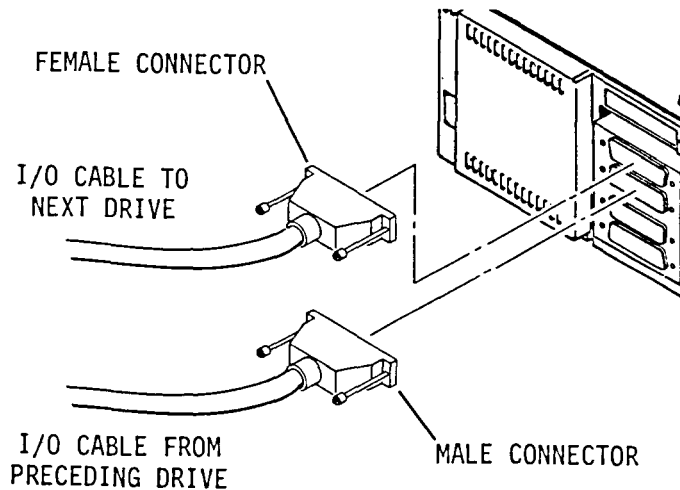

11F349

SPINDLE SYNC CABLE

Spindle synchronization is a feature provided on P8BY2A drives. A spindle synchronization cable connects each of these drives and allows the spindle in each drive to synchronize to an external clock.

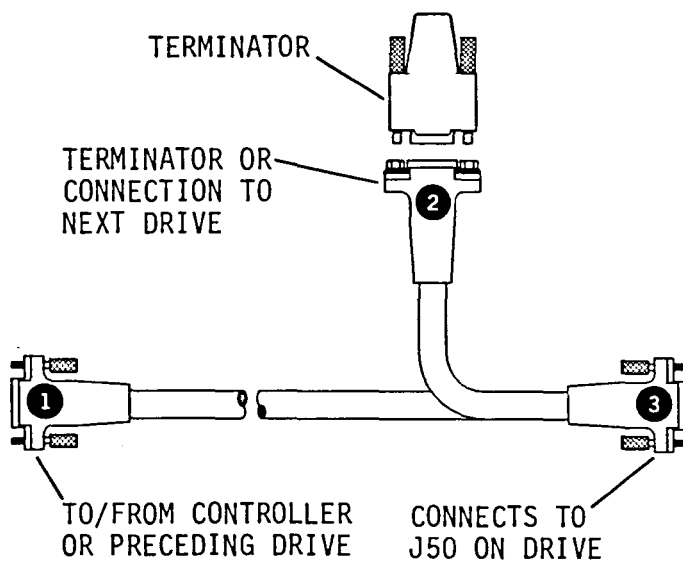

11F386

THE TOP COVER

The top cover ensures proper air flow and protects the internal components of the drive. An access hole in the top cover allows setting the switches on the circuit board without removing the cover.

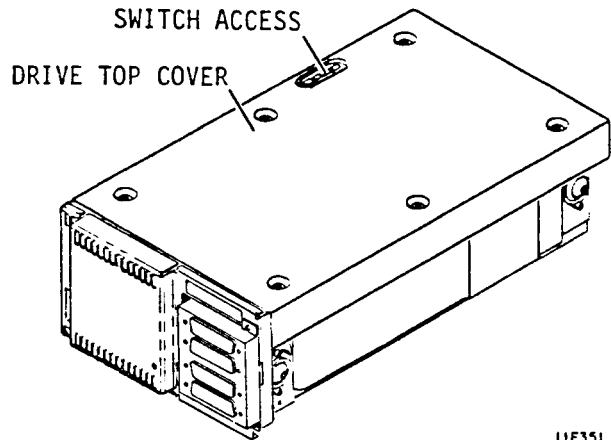

11F351

THE REAR PANEL

The rear panel protects the I/O board and connectors at the rear of the drive, and ensures proper air flow. An optional fan and rear panel assembly is available and must be used if the optional power supply is not used or is not mounted in-line with the drive. Access to a row of DIP switches is provided through a hole at the left side of the rear panel.

The appearance of the rear panel can vary. P8Y2A drives have an I/O board that has an additional, spindle sync connector located just below the row of DIP switches.

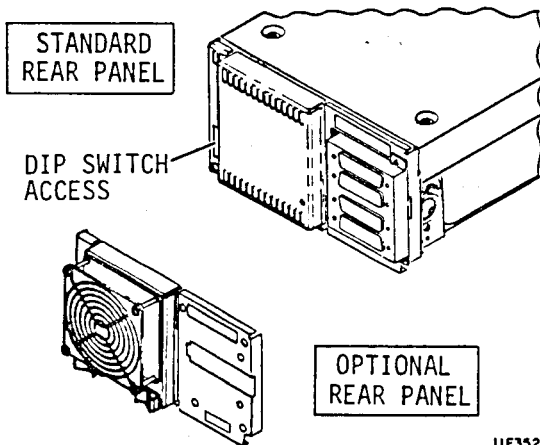

11F352A

THE MODULE

The module is a sealed unit containing the actuator, discs, heads, motor, spindle, and the other electrical and mechanical parts needed for drive operation.

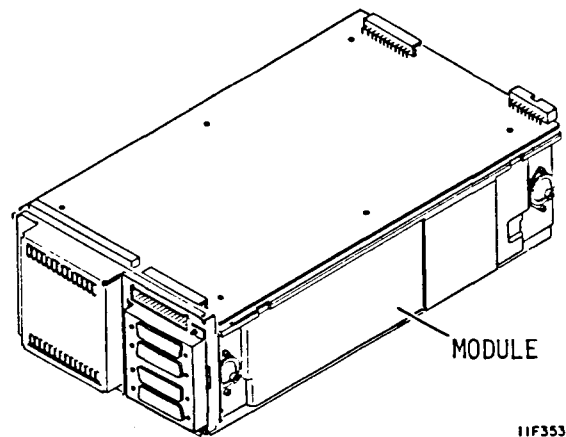

11F353

The discs inside the module are mounted on a spindle that is coupled directly to the drive motor. The drive motor spins the discs at 3600 r/min. Disc rotation creates air currents inside the sealed module that allow the heads to fly over the disc surface.

The actuator assembly holds the heads and moves them over the spinning discs. 15 data heads (14 on drives with the two-head parallel feature) are used for data transfers to and from the disc. One servo head senses actuator position by reading the prerecorded servo information from the servo surface. The information read by the servo head controls the movement of the actuator and the heads attached to it.

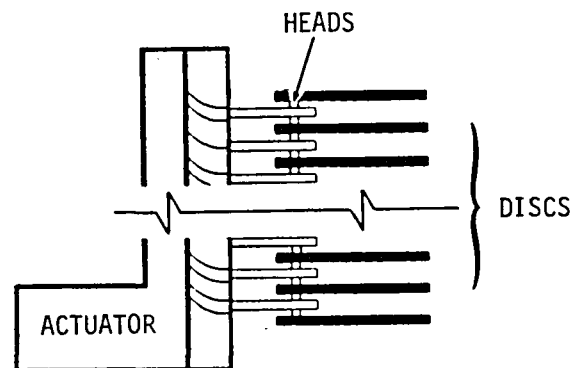

11F310B

THE MODULE (CONTD)

The actuator has a voice coil that moves within a permanent magnetic field in response to signals from the servo control circuits. Movement of the voice coil moves the heads in an arc, across the rotating discs, to any one of the available data tracks.

The heads rest in a landing zone on the disc surface when the drive is not in use. This landing zone is beyond the data zone and the actuator locks in this position when the drive is stopped.

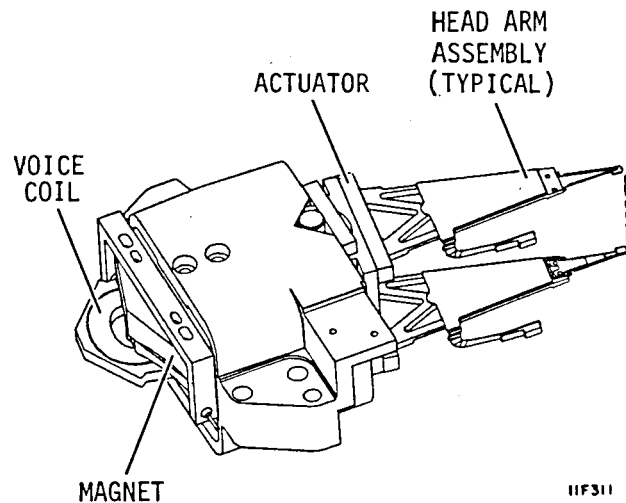

CIRCUIT BOARDS

The drive has two circuit boards. A control board is mounted on the module under the top cover. This board controls read, write, seek, and the other drive control functions. The control board on drives with the two-head parallel feature has two separate read/write channels, one for each head used in read/write operations.

The I/O board at the back of the drive controls data formatting and transfer (I/O) operations. It also has the connectors to which the I/O and spindle sync cables (when used) are connected.

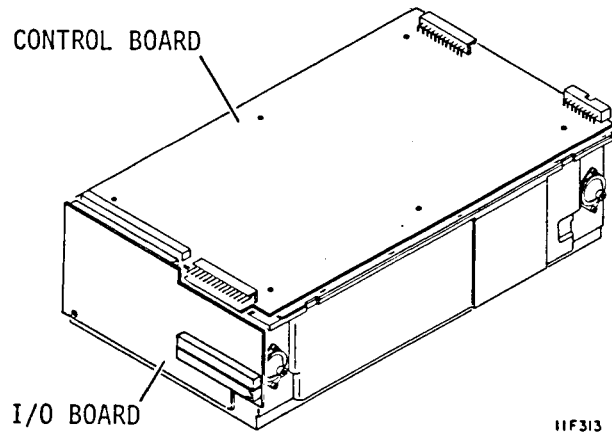

COOLING PROVISIONS

When the optional power supply is mounted in-line with the drive, air flows out of the power supply, through the drive, and out the rear panel.

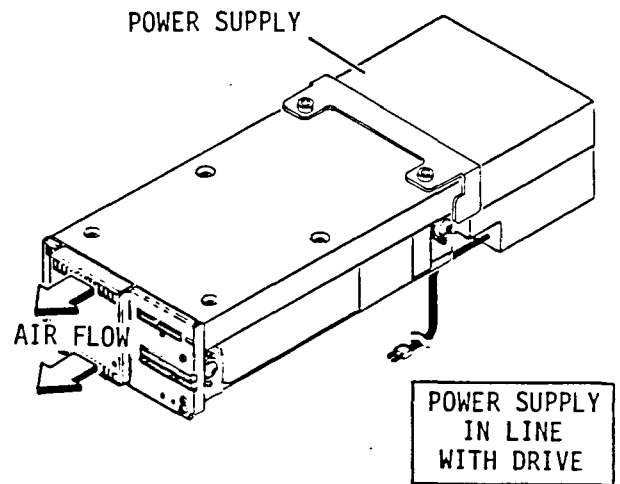

The optional rear panel is needed when the power supply is not mounted in-line with the drive. The fan forces air across the interior of the drive.

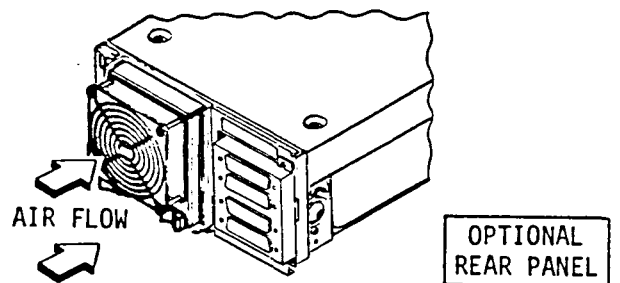

11F355A

OPERATOR PANEL

This optional operator panel provides external control of the drive. It contains the switches and indicators you use to control the drive. These controls and indicators are described in section 3 of this manual.

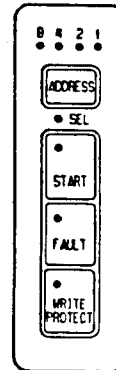

11F314

STATUS/CONTROL PANEL

The optional status/control panel is another type of control panel. It has the same controls and indicators as the operator panel, but it also has a maintenance panel that allows running of offline diagnostic tests and reading of various status conditions. Controls and indicators used by the operator are described in section 3.

The controls and indicators on the maintenance panel are described in the maintenance manual.

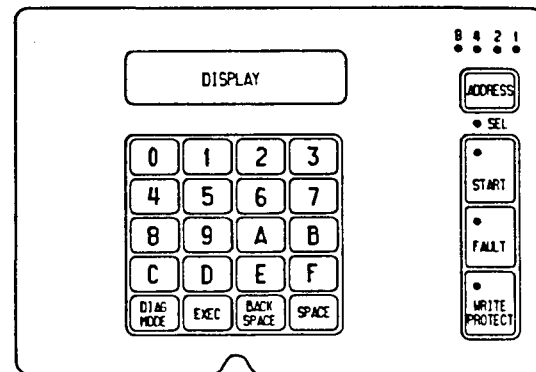

11F315

HOW THE DRIVE WRITES AND READS.

The drive has all the circuits and mechanical devices needed to record data on and recover it from the discs.

During a write operation, the drive receives commands and data from the controller. The drive interprets the commands and then records (writes) the data. In read operations, the drive receives commands from the controller, interprets them, recovers the data (reads it) from the discs, and then transfers it back to the controller. Two-head parallel drives can write and read using two heads in one of four modes. More information about two-head parallel drives is provided at the end of this section. Power needs are met by the power supply.

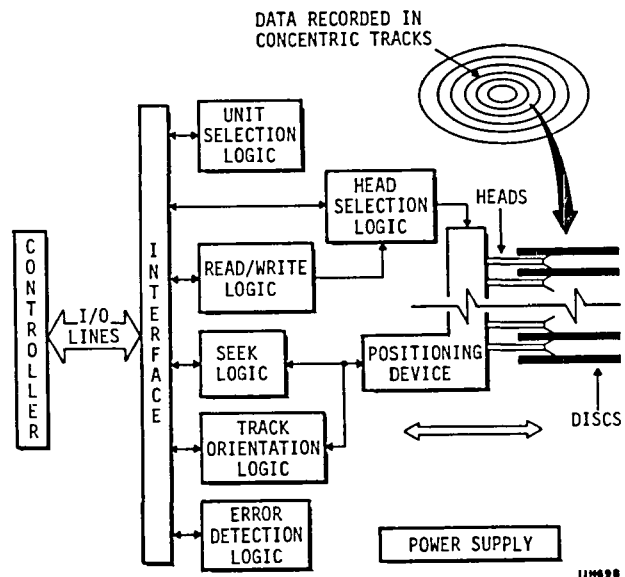

The drive circuits control the data storage (writing) and retrieval (reading) process. The read and write processes use electromagnetic devices called heads that can be moved to various tracks (positions) on the recording surfaces of the rotating discs. One head is provided for each disc surface. The heads are positioned such that data is written in concentric tracks around the disc surfaces.



11F317

HOW THE DRIVE WRITES AND READS (CONTD)

The controller instructs the drive to seek (move the heads) to a given cylinder. Cylinders are formed by imaginary lines that connect the same track on each recording surface.

Having reached the specified cylinder, the controller directs the drive to select the head located over the track where the read or write operation will occur.

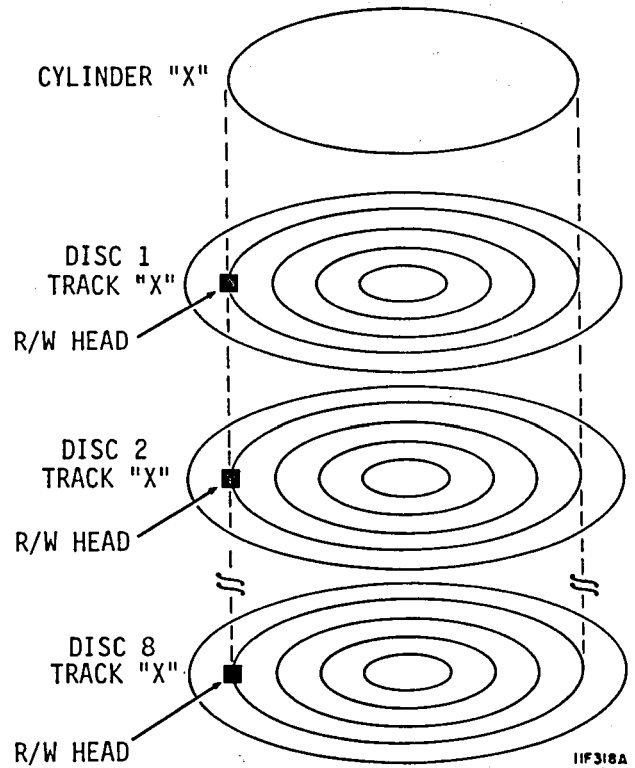

The drive locates the part of the track where the data is to be written or read. This is called track orientation. The controller uses signals from the drive to determine the position of the head on the track.

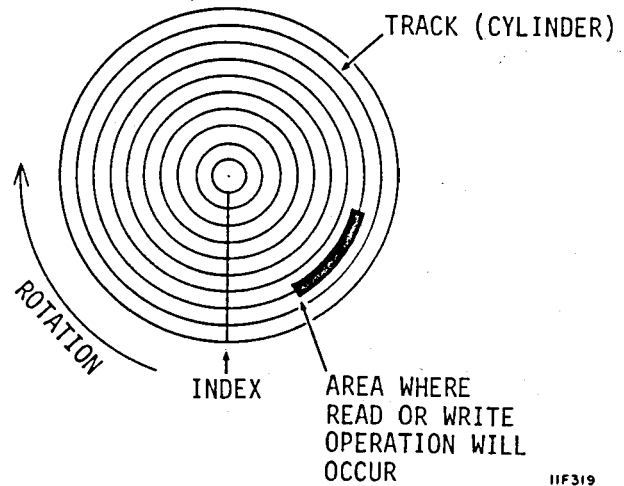

HOW THE DRIVE WRITES AND READS (CONTD)

The controller commands the drive to read or write the data when the desired location on the track is reached.

During a read operation, the drive recovers (reads) data from the discs and sends it to the controller.

During a write operation the drive receives data from the controller, processes it, and records (writes) it on the discs.

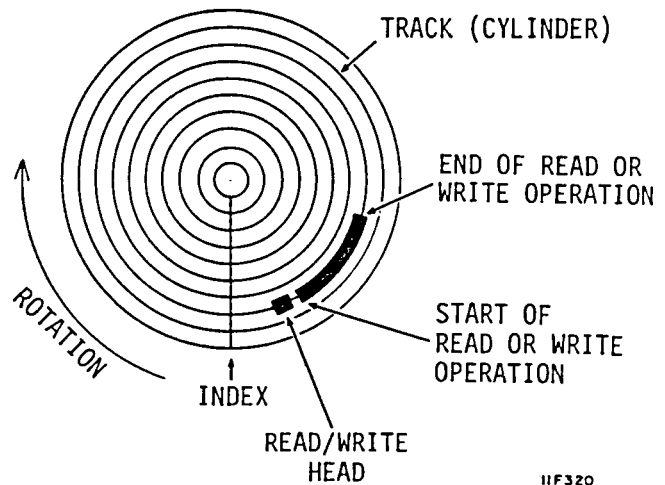

The drive recognizes certain errors that may cause faults during its operation. If a fault occurs, a signal is sent to the controller or an indicator on the drive is turned on.

Both errors and faults are communicated to the controller via status responses.

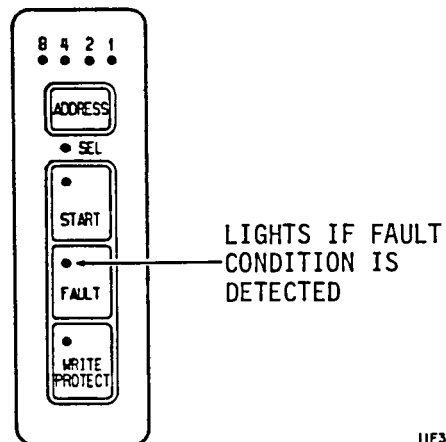

TWO-HEAD PARALLEL DRIVES

Drives that have the two-head parallel feature can read and write using two heads. These drives have two read/write channels and control circuits designed specifically for two-head operation. Channel 0 writes data to or reads data from head arms 1, 3, 5, and 7. Channel 1 writes data to or reads data from head arms 2, 4, 6, and 8. A write/read operation that specifies logical head 0 for example, selects heads 4 and 6 on arms 7 (channel 0) and 8 (channel 1). Two-head parallel drives can operate in any one of the four modes described below.

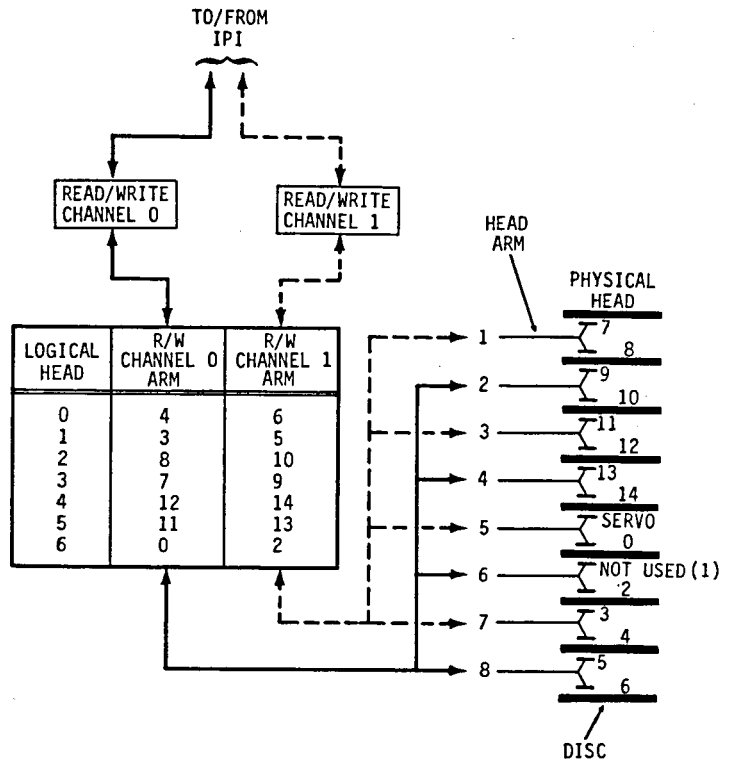

11F3408

BIT INTERLEAVE MODE

In this mode, the 16 bits of each word transferred across the IPI are alternately written to the two heads. The odd bits go to read/write channel 0 and the even bits go to read/write channel 1 starting with the MSB.

When reading, words are formed by taking bits alternately from the two heads. Odd bits are taken from read/write channel 0 and even bits from read/write channel 1, starting with the MSB.

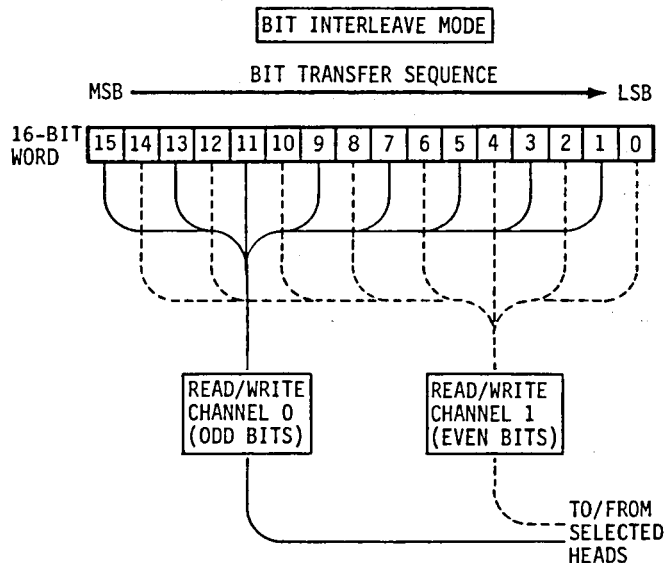

BYTE INTERLEAVE MODE

In this mode, the two bytes of each 16 bit word transferred across the IPI are alternately written to the two heads. Even bytes go to read/write channel 0 and the odd bytes go to read/write channel 1.

When reading, words are formed by taking bytes alternately from the two heads. Even bytes are taken from read/write channel 0 and odd bytes from read/write channel 1.

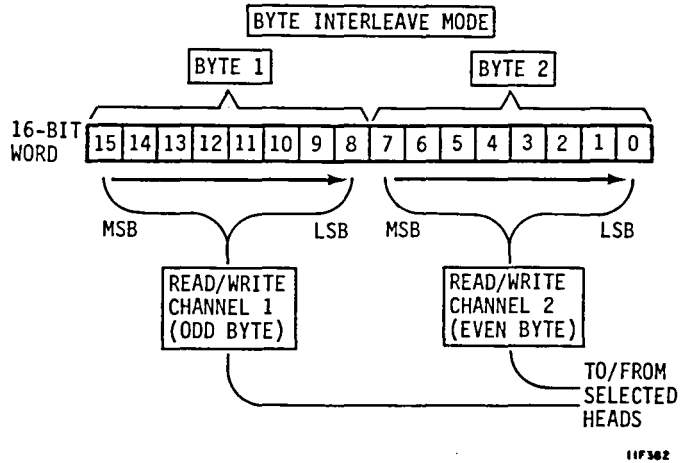

WORD INTERLEAVE MODE

In this mode, the 16 bit words transferred across the IPI are alternately written to the two heads. Even words go to read/write channel 0 and odd words go to read/write channel 1.

When reading, words are taken alternately from the two heads. Even words are taken from read/write channel 0 and odd words from read/write channel 1.

ONE-HEAD MODE

In this mode the drive reads and writes using only one head. This mode is normally used only in the factory.

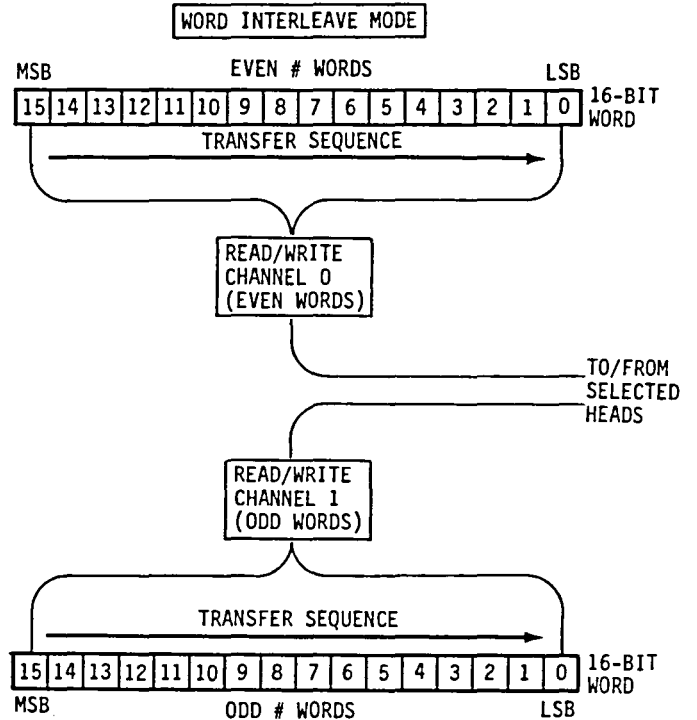

DRIVE SPECIFICATIONS

Characteristics	Conditions	Specifications
Size	Dimensions	See Section 2
Capacity	Weight (Drive only)	14.5 kg (32 lb)
	Weight (Power Supply only)	3.2 kg (7.0 lb)
	Total Capacity (Unformatted)	851.14 MB
	850 MB Drives	1153.65 MB
Physical	1153 MB Drives	1236.06 MB
	1230 MB Drives	
	Bytes per track (Unformatted)	41 088 bytes
	850 MB Drives	50 400 bytes
Recording	1153 MB Drives	50 400 bytes
	1230 MB Drives	
	Number of discs	9
	Movable data heads	15 (14 on 1153 MB)
Transfer rate	Servo Heads	1
	Heads/Surface	1
	Logical cylinders	1381 (0-1380)
	850 MB Drives	1635 (0-1634)
Transfer rate	1153 MB Drives	1635 (0-1634)
	1230 MB Drives	
	Modulation	2-7 Code
	3600 r/min	
Transfer rate	850 MB Drives	19.72 MHz (2.46 MB/s)
	1153 MB Drives	48.40 MHz (6.0 MB/s)
	1230 MB Drives	24.19 MHz (3.024 MB/s)
Continued		

DRIVE SPECIFICATIONS (CONTD)

Characteristics	Conditions	Specifications
Latency	Average	8.33 milliseconds (disc rotation speed at 3600 r/min)
	Maximum	16.83 milliseconds (disc rotation speed at 3564 r/min)
Seek Time	0 to max. cyl.	30 milliseconds max.
	Average	15 milliseconds
	Single Track	4 milliseconds average
Start Time		90 seconds max.
Stop Time		60 seconds max.

SECTION 2. INSTALLING THE DISC DRIVE

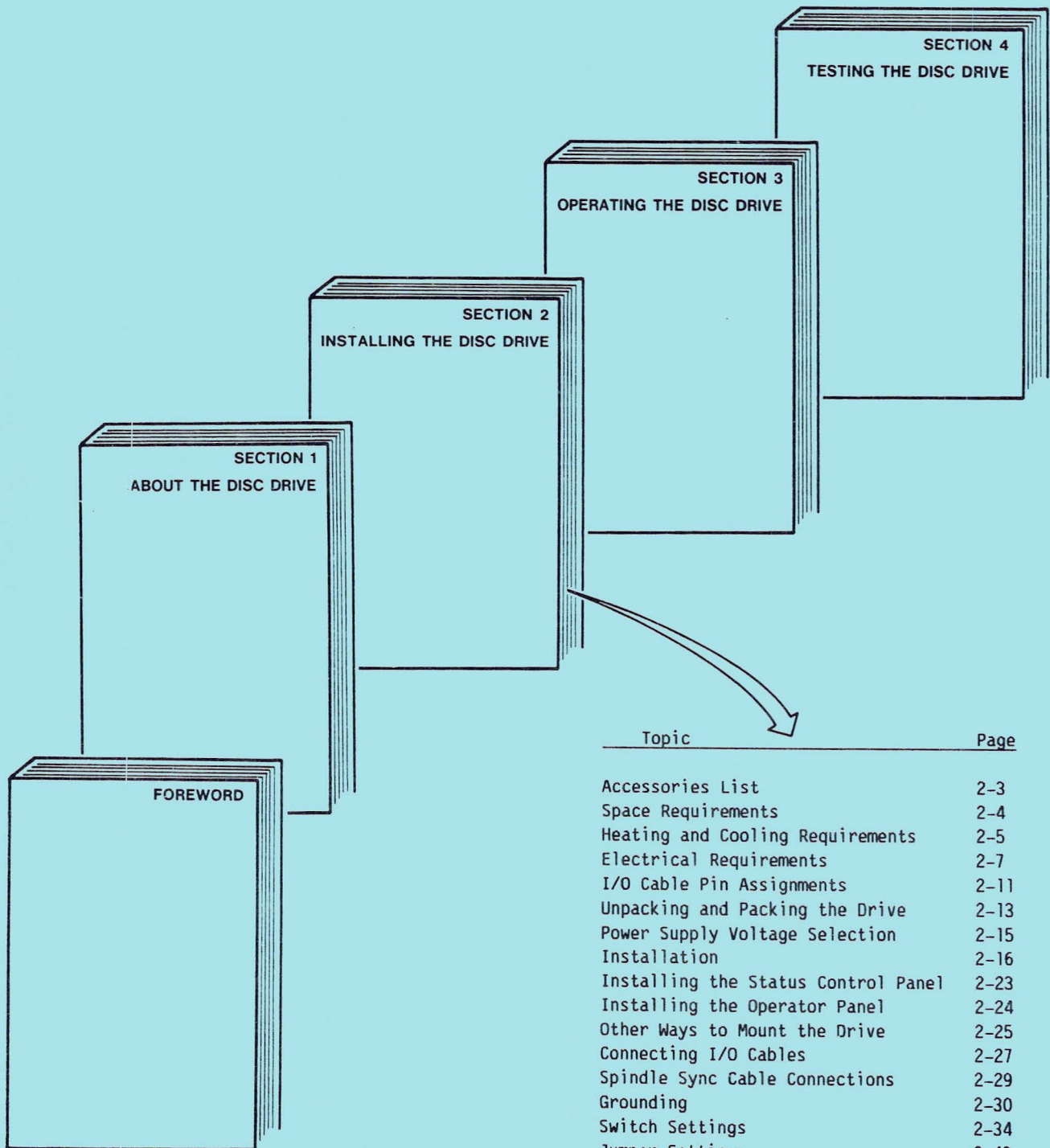

Topic	Page
Accessories List	2-3
Space Requirements	2-4
Heating and Cooling Requirements	2-5
Electrical Requirements	2-7
I/O Cable Pin Assignments	2-11
Unpacking and Packing the Drive	2-13
Power Supply Voltage Selection	2-15
Installation	2-16
Installing the Status Control Panel	2-23
Installing the Operator Panel	2-24
Other Ways to Mount the Drive	2-25
Connecting I/O Cables	2-27
Spindle Sync Cable Connections	2-29
Grounding	2-30
Switch Settings	2-34
Jumper Settings	2-43
Sweep Cycle Information	2-45
Initial Checkout	2-47
Adding an Operator or Status/Control Panel	2-51

THINGS TO CONSIDER BEFORE YOU BEGIN INSTALLING THE DRIVE

The installation procedures in this manual apply to a drive and power supply that mount side-by-side with another drive and power supply in a 2X drawer. The 2X drawer mounts on slides into a 483 mm (19 in) standard rack. The slides allow outward extension of the drawer for ease of maintenance.

Successful installation of the drive starts with a plan that considers the following:

- Protecting the Drive From Electrostatic Discharge
- Accessories Needed
- Space Requirements
- Heating and Cooling Requirements
- Electrical Requirements
- Grounding Requirements
- Interface Requirements

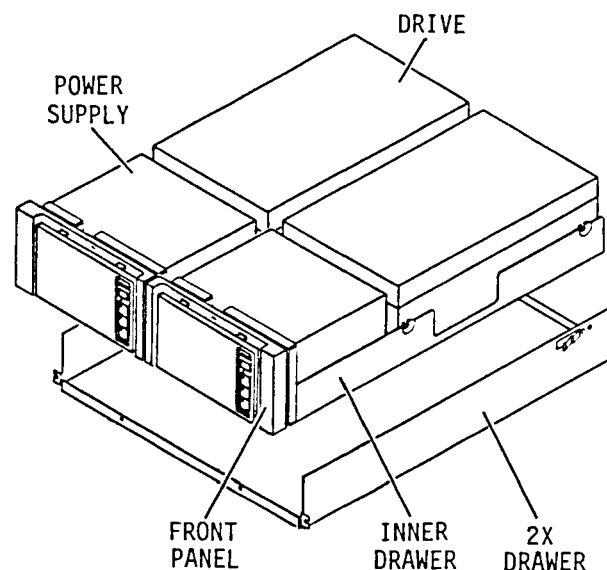

11F268A

THE INSTALLATION PROCESS

The installation process can vary depending on how the drive and power supply are mounted, how dc power is supplied to the drive, if the fan kit is required, and whether an optional operator or status/control panel is used. Each procedure in this section is presented in the sequence it must be performed. In some cases you may find it more convenient to make switch settings on the power supply and the drive before they are mounted. If a procedure does not apply, skip it and go to the next procedure.

The topic Other Ways To Install the Drive provides information for those installations where a 2X drawer is not used. Details for alternate mounting are beyond the scope of this manual.

PROTECTING THE DRIVE FROM ELECTROSTATIC DISCHARGE

All drive electronic assemblies are sensitive to static electricity, due to the electrostatically sensitive devices used within the drive circuitry. Although some of these devices such as metal-oxide semiconductors are extremely sensitive, all semiconductors as well as some resistors and capacitors may be damaged or degraded by exposure to static electricity.

Electrostatic damage to electronic devices may be caused by a direct discharge of a charged conductor, or by exposure to the static fields which surround charged objects. To avoid damage to drive electronic assemblies, you must observe the following precautions when servicing the drive:

- Ground yourself to the drive whenever the drive electronics are or will be exposed. Connect yourself to ground with a wrist strap (refer to Accessories in this section for part numbers). Connection may be made to any metal assembly. As a general rule, remember that you, the drive, and the circuit boards must all be at ground potential to avoid potentially damaging static discharges.
- Keep boards in conductive bags. When circuit boards are not installed in the drive, keep them in conductive static shielding bags (refer to Accessories in this section for part numbers). These bags provide absolute protection from direct static discharge and from static fields surrounding charged objects. Remember that these bags are conductive and should not be placed where they might cause an electrical short circuit.
- Remove boards from bags only when you are grounded. All boards received from the factory are in static shielding bags, and should not be removed unless you are grounded.
- Turn off power to the drive before removing or installing circuit boards.
- Do not touch pins on power supply connector J15. The power supply circuitry is sensitive to electrostatic discharge.
- Never use an ohmmeter on any circuit boards.

ACCESSORIES

PART NUMBER	DESCRIPTION
12263496 12263623 12263624 12263625 12263626 12263499 12263627	Static Ground Wrist Strap, 6 1/2 to 8 inch wrist Static Ground Wrist Strap, up to 6 1/2 inch wrist Static Shielding Bag, 5 x 8 inch Static Shielding Bag, 8 x 12 inch Static Shielding Bag, 10 x 12 inch Static Shielding Bag, 14 x 18 inch Static Shielding Bag, 16 x 24 inch
47188871 47188872 75168331 75168346 15165427 92588100 92588101 92588102	AC Short Power Cord Set (60 Hz) AC Short Power Cord Set (50 Hz) AC Power Cable, 5-15P (60 Hz) AC Power Cable, 6-15P (60 Hz) AC Power Cable (50 Hz). DC Power Cable, 63.5 mm (2.5 inch) DC Power Cable, 152 cm (60 inch) DC Power Cable, 244 cm (96 inch)
47191101 47191108 47191102 47191103 47191104 47191105 47191106 15458851	I/O Cable, 10 foot (3.05 metre) long I/O Cable, 15 foot (4.57 metre) long I/O Cable, 25 foot (7.62 metre) long I/O Cable, 50 foot (15.25 metre) long I/O Cable, 75 foot (22.9 metre) long I/O Cable, 100 foot (30.5 metre) long I/O Cable, 150 foot (45.7 metre) long I/O Terminator, Shielded
70882721 70882722 70882723 70882724 70882725 70882726 70882711	Spindle Sync Cable, 18 inch (0.46 metre) long Spindle Sync Cable, 3 foot (0.92 metre) long Spindle Sync Cable, 6 foot (1.83 metre) long Spindle Sync Cable, 10 foot (3.05 metre) long Spindle Sync Cable, 25 foot (7.62 metre) long Spindle Sync Cable, 50 foot (15.24 metre) long Terminator, Spindle Sync
24534808 40125601 10126403	Ground Strap (Specify length) Ground Lug Lockwasher, #10 (For grounding)
All I/O cables are shielded	

SPACE REQUIREMENTS

Dimensions for the drive and optional power supply are shown on this page.

Be sure to refer to Other Ways to Install the Drive later in this section if the drive and power supply will be mounted in a custom enclosure or cabinet.

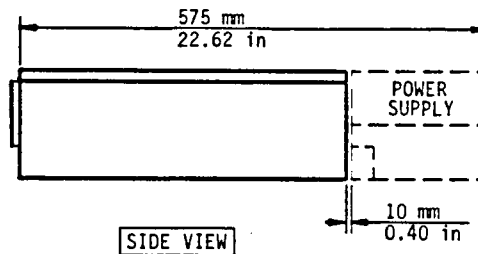
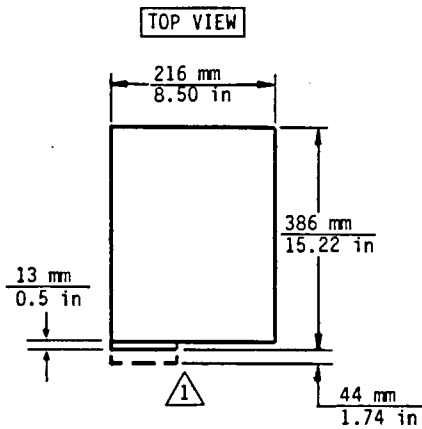
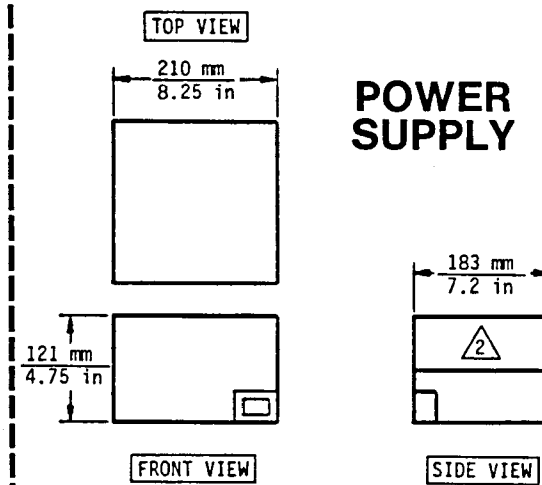

NOTES:

- 1 COOLING FAN MOUNTS ON REAR PANEL WHEN POWER SUPPLY IS NOT MOUNTED IN LINE WITH DRIVE.
- 2 COOLING FAN IS INSIDE POWER SUPPLY.
- 3 DIMENSIONS ARE NOMINAL.

11F269

HEATING AND COOLING REQUIREMENTS

The environmental requirements listed below must not be exceeded regardless how the drive is mounted.

Conditions	Characteristics	Specifications
TEMPERATURE		
Storage (Packed)	Range	-10°C to 50°C (14°F to 122°F)
	Maximum change per hr	15°C (27°F)
Transit (Packed)	Range	-40°C to 60°C (-40°F to 140°F)
	Maximum change per hr	20°C (36°F)
Operating	Range	10°C to 45°C (50°F to 113°F)
	Maximum change per hr	15°C (27°F)
RELATIVE HUMIDITY		
Storage (Packed)	Range	5% to 95%
Transit (Packed)	Range	5% to 95%
Operating	Range	20% to 80% (No condensation allowed)
Continued		

HEATING AND COOLING REQUIREMENTS (CONTD)

Conditions	Characteristics	Specifications
BAROMETRIC PRESSURE (STANDARD DAY)		
Storage (Packed)	Range	-305 m to 3000 m (-1000 to 10 000 ft) 104 kPa to 69 kPa (30 in Hg to 20 in Hg)
Transit (Packed)	Range	-305 m to 12 192 m (-1000 to 40 000 ft) 104 kPa to 19 kPa (30 in Hg to 6 in Hg)
Operating	Range	-305 m to 3000 m (-1000 to 10 000 ft) 104 kPa to 69 kPa (30 in Hg to 20 in Hg)

ELECTRICAL REQUIREMENTS

WARNING

This unit has a single phase power supply with a capacitor input filter (sometimes called a switching type supply). If power comes from a 3-phase, 4-wire, wye branch or feeder circuit, ensure the circuit meets the latest requirements of the United States National Electrical Code. Failure to meet these requirements may cause hazardous conditions due to high currents and heating in the neutral conductors and transformers supplying the unit.

Specifications	Nominal Values*	
	100 - 120 V ac	208 - 240 V ac
Voltage Range	85 to 132 V	177 to 264 V
Nominal Line Frequency	50/60 Hz	50/60 Hz
Frequency Range	48.0 to 62.0 Hz	48.0 to 62.0 Hz
Phase	Single Phase	Single Phase
Power Consumed*	0.147 - 0.153 kW 0.151 - 0.152 kW**	0.149 - 0.144 kW 0.151 - 0.152 kW**
Line Current*	2.60 - 2.30 A 2.24 - 1.93 A**	1.60 - 1.40 A 1.51 - 1.22 A**
Power Factor*	0.57 - 0.56 0.67 - 0.66**	0.46 - 0.43 0.67 - 0.66**
<p>* Nominal values with discs rotating and carriage moving. ** Values are for drives with two-head parallel feature.</p>		

ELECTRICAL REQUIREMENTS (CONTD)

Start current waveforms are shown below.

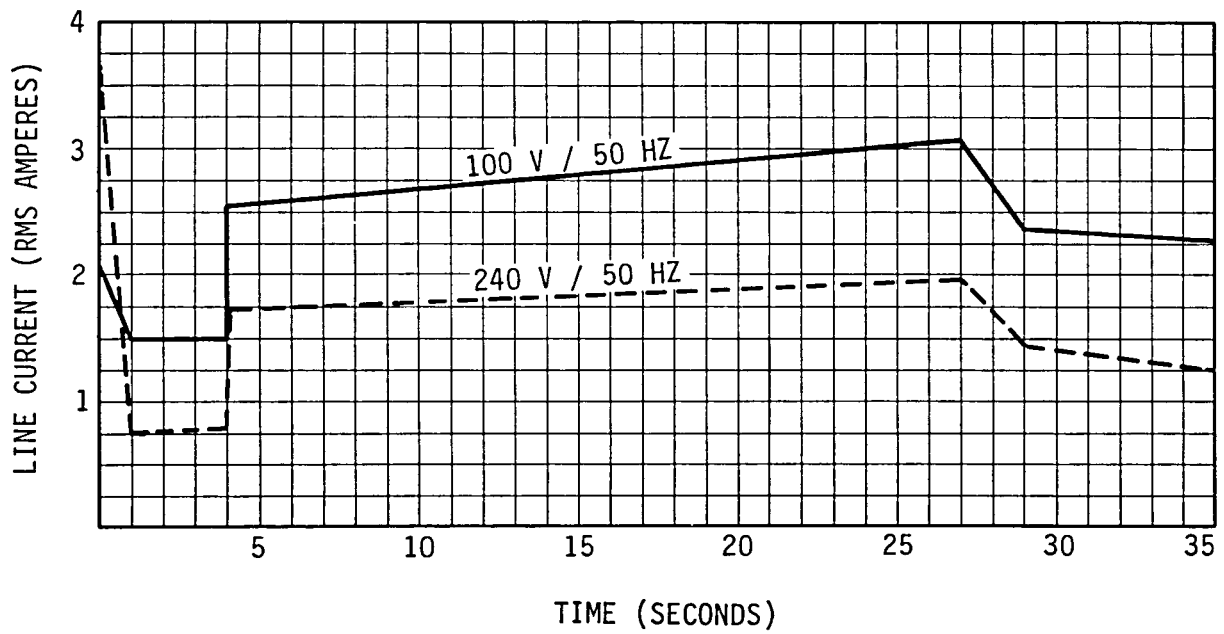
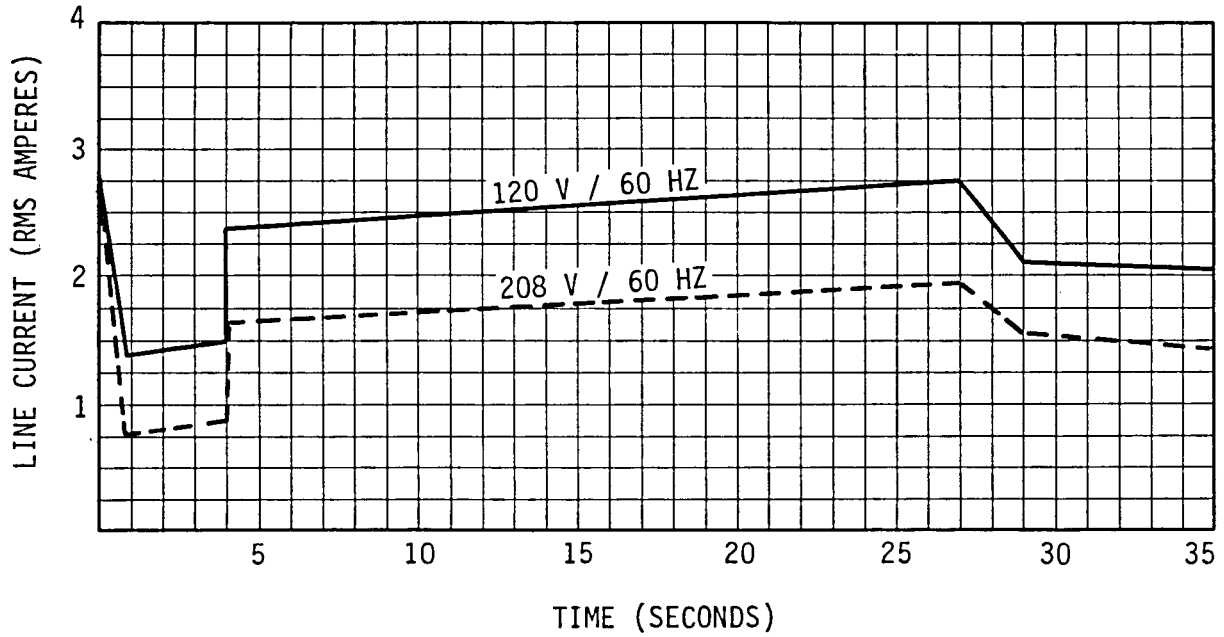

11H96A

INTERFACE REQUIREMENTS

This drive is a two channel device, so it can be shared by two controllers if necessary. It can be connected in either a star or daisy chain I/O configuration.

The four I/O connectors at the back of the drive accept the I/O cables that connect it to the system. J3-1 and J3-2 are the connectors for port A and B to which a terminator or the I/O cable to the next drive in a string are attached. J4-1 and J4-2 are the I/O inputs for port A and B respectively.

A terminator must be installed on J3-1 and J3-2 only if they are not used, AND an I/O cable is connected to J4-1 (port A) or J4-2 (port B). Unused ports (i.e., no I/O input) must be disabled as described in Setting the I/O Board Switches.

Refer to the Accessories list in this section for I/O cable and terminator part numbers. When selecting I/O cables, ensure they are long enough to permit full extension of the drive from the cabinet (if applicable).

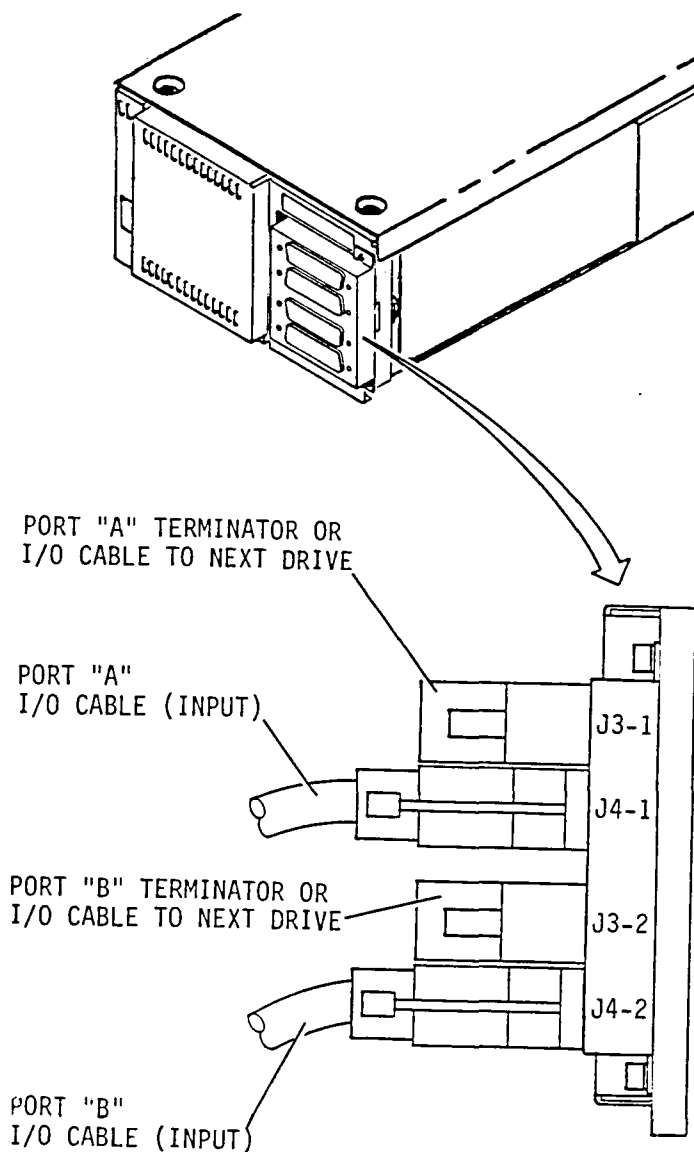

11F354

STAR I/O CABLING

A star I/O cabling scheme can be used if the controller has an I/O connector available for each drive in the system. In dual port systems, both controllers must have an I/O connector available for each drive in the system if both controllers are to have access to all drives.

I/O cable length cannot exceed 45.7 m (150 ft). Unused ports must be disabled as described in Setting the I/O Board Switches.

The number of I/O cables and terminators required in this cabling scheme is doubled if the dual port feature is used.

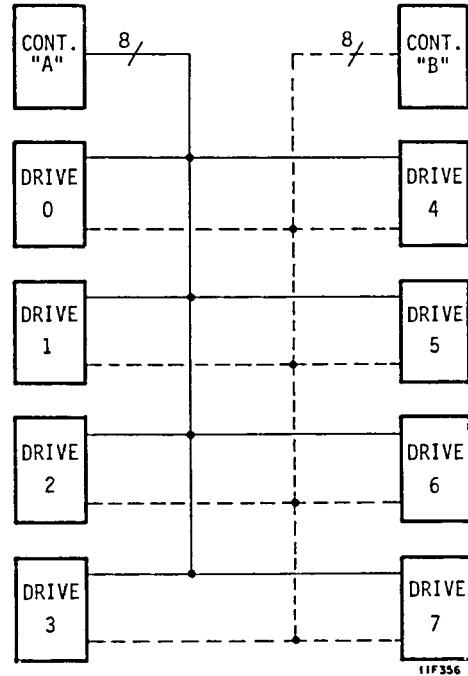

DAISY CHAIN I/O CABLING

Daisy chain I/O cabling must be used if the controller has only one drive I/O connector. In this scheme, an I/O cable connects the first drive to the controller. Additional I/O cables connect the first drive to the second, second to the third, etc.

A maximum of eight drives can be connected in a daisy chain. Unused ports must be disabled as described in Setting the I/O Board Switches.

The maximum cumulative I/O cable length in a daisy chain system is 45.7 m (150 ft). The number of I/O cables and terminators required in this cabling scheme is doubled if the dual port feature is used.

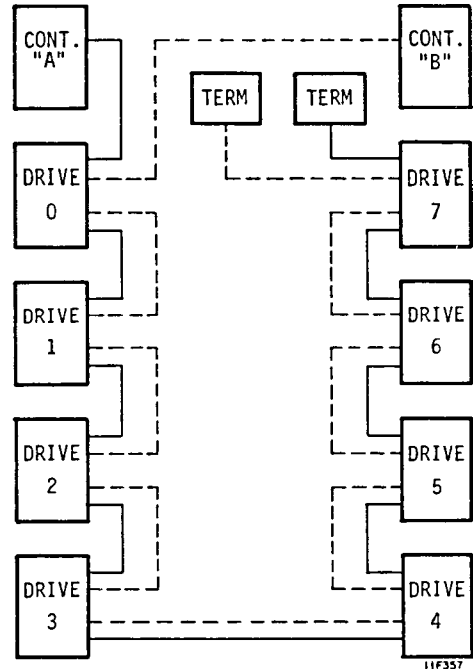

I/O CABLE PIN ASSIGNMENTS

Signal Name	(+) Pin Number	(-) Pin Number
DC Ground	1	34
Select Out	43	27
Master Out	45	29
Sync Out	41	25
Sync In	15	48
Slave In	39	23
Attention In	20	4
Bus A - Bit 0	13	46
Bus A - Bit 1	30	14
Bus A - Bit 2	22	6
Bus A - Bit 3	26	10
Bus A - Bit 4	11	44
Bus A - Bit 5	28	12
Bus A - Bit 6	37	21
Bus A - Bit 7	5	38
Bus A - Parity	47	31
Bus B - Bit 0	32	16
Bus B - Bit 1	49	33
Bus B - Bit 2	3	36
Bus B - Bit 3	7	40
Bus B - Bit 4	24	8
Bus B - Bit 5	9	42
Bus B - Bit 6	18	2
Bus B - Bit 7	35	19
Bus B - Parity	17	50

THE SPINDLE SYNC FEATURE

Spindle synchronization is a feature found only on P8Y2A drives. It is not essential that you use this feature. If used, this feature will synchronize the spindle on each drive in a daisy chain to an external clock.

Drives with this feature have another connector (J50) on the rear panel just below the DIP switches. The spindle motor control circuits connect to the external clock using the special spindle sync cable.

Refer to Spindle Synchronization Information in this section for a description of this feature and how to use it.

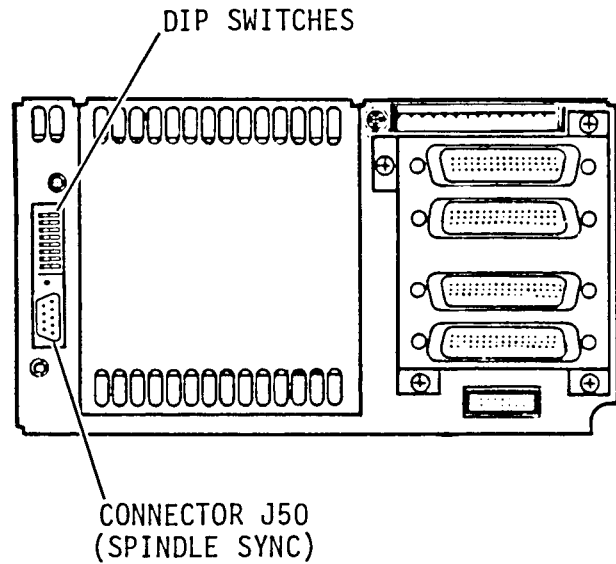

11F385

THE SPINDLE SYNC CABLE

A special, spindle sync cable connects each drive to the external clock. A terminator is installed on the unused cable connector at the last drive in the string.

Part numbers for the spindle sync terminator and cables are provided in the Accessories list in this section.

The number (1, 2, 3) on each connector helps identify which connector to use when making connections shown on page 2-29.

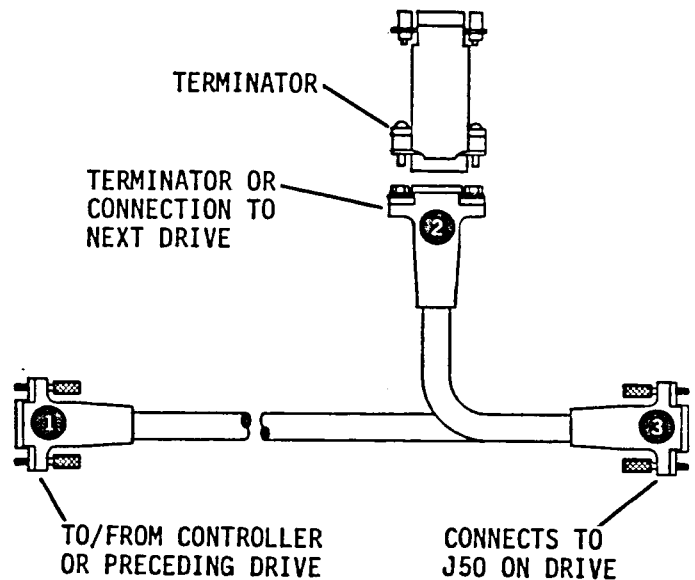

11T71

UNPACKING THE DRIVE

Unpack the drive using the unpacking instructions supplied with it. Save all packing materials for use if the drive must be shipped in the future.

Unpack the 2X drawer, two slide mounts, and slide mount hardware kit if applicable.

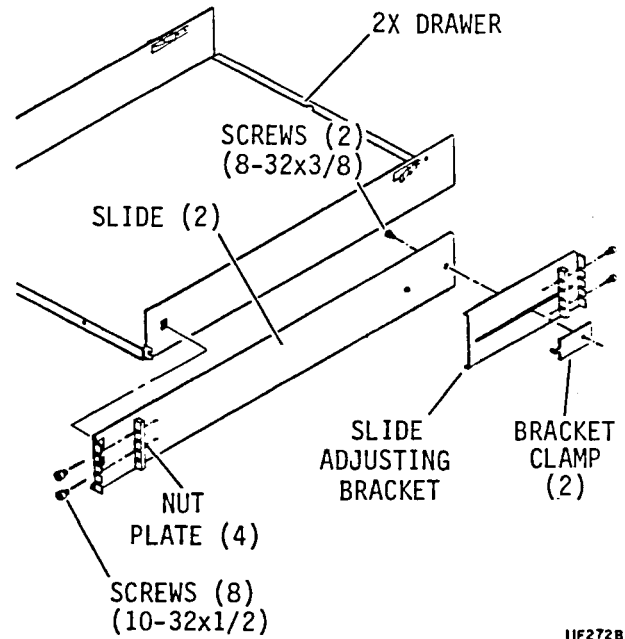

11F272B

Unpack the ac and dc power cables. The length and style of the ac and dc power cables can vary. These cables are accessories, ordered for your specific application.

AC power cords are either one or two pieces and can have one of several plug styles.

DC power cables are available in various lengths to enable remote mounting of the power supply.

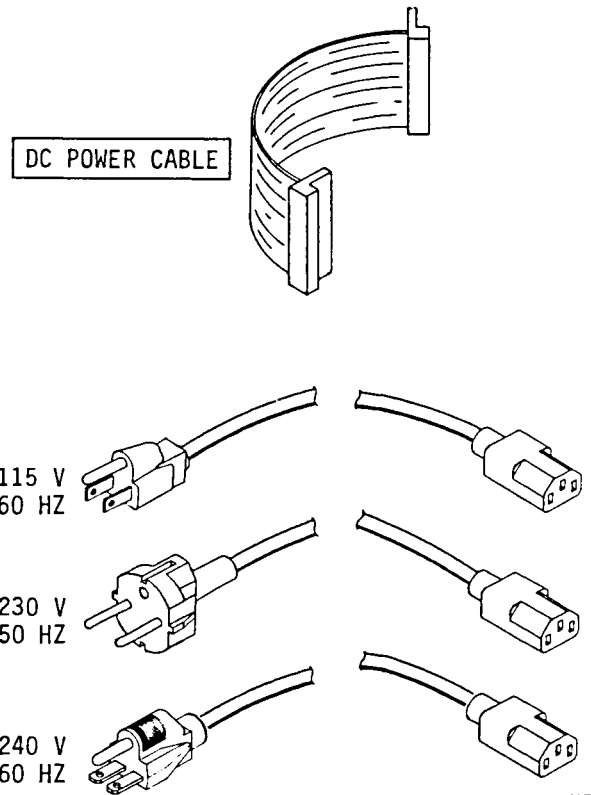

11F273A

UNPACKING THE DRIVE (CONTD)

Open the sealed vapor barrier bag and remove the drive and power supply.

Check all items against the shipping bill. Report discrepancies, missing items, damaged equipment, etc., to the account representative for the equipment.

INSPECTING THE DRIVE

Inspect the drive, power supply, and accessory items for possible shipping damage. Claims for shipping damage must be filed with the carrier involved.

PACKING THE DRIVE

If it is necessary to ship the drive at some time in the future, pack it using the original packing materials. Packing instructions can be obtained at the address shown. Follow the packing instructions carefully to ensure the drive is undamaged in shipment.

Specify the exact equipment number and series code shown on the drive equipment identification label.

Seagate Technology, Inc.
Customer Services
12701 Whitewater Drive
Minnetonka, MN 55343

Phone: 1-800-382-6060
Fax: (612) 931-8817

HOW TO CHECK THE POWER SUPPLY VOLTAGE SELECTION

The power supply is set at the factory to operate from either a 115 V or 230 V ac input power source. A matching power cord must be used. The position of the voltage select plate at the side of the power supply determines voltage selection. If it matches the ac power source, skip the following procedure. Use the following procedure if the voltage setting must be changed.

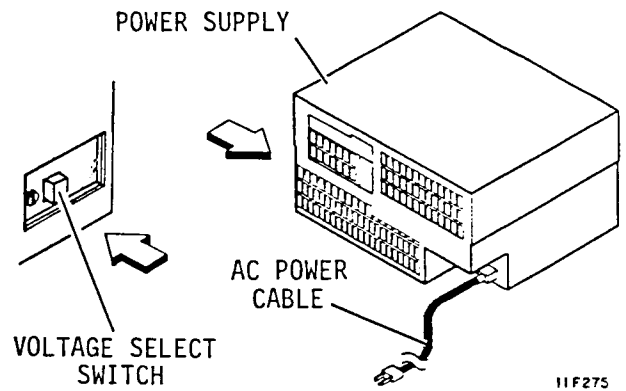

CAUTION

Power supply could fail if voltage select is not matched with input ac voltage.

HOW TO CHANGE THE POWER SUPPLY VOLTAGE SELECTION

1. Disconnect ac power cord from power supply.
2. Remove screw securing voltage select plate to power supply. Remove plate. Save plate and screw.
3. Set voltage select switch to desired range.
4. Reverse voltage select plate and install it on power supply to lock switch in desired range. Plate must show new voltage setting.
5. Install an ac power cord that matches selected voltage.

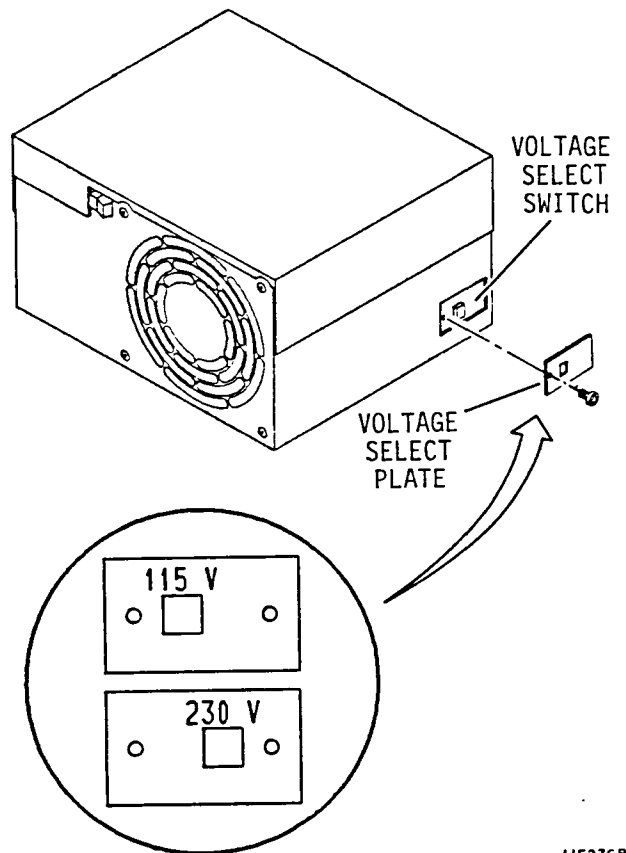

INSTALLING THE 2X DRAWER IN A RACK

Use this procedure to install the optional 2X drawer into a standard rack.

1. Remove screws from rack mounting kit. The four smaller screws attach the slide adjusting brackets to slides and inner drawers to the 2X drawer.
2. Loosely attach slide adjusting bracket to each slide with bracket clamp and screw.

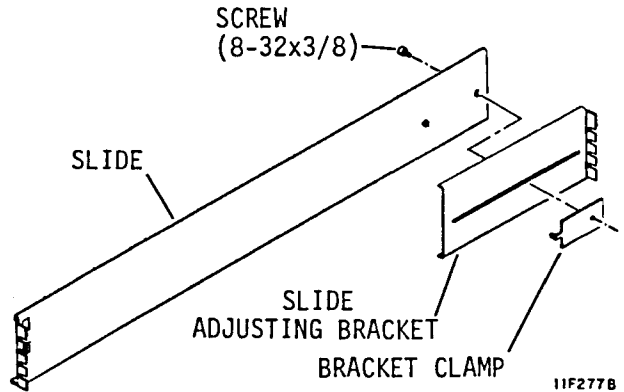

3. Loosely attach screws and nut plates for each slide to rack. The screws go into top and third holes at front of rack and in top and bottom holes at rear of rack.

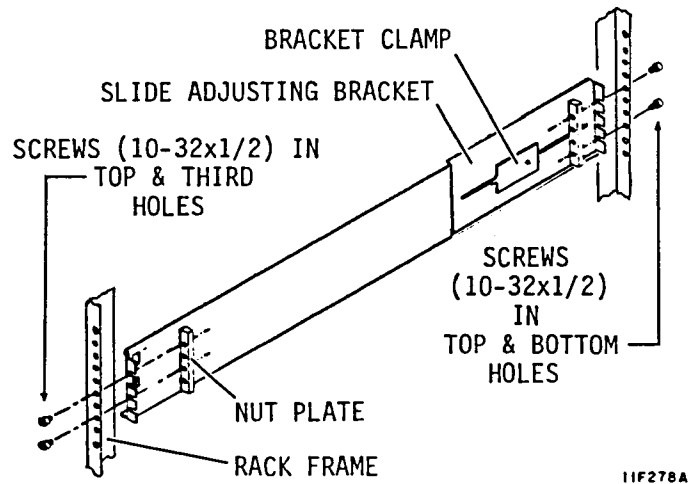

INSTALLING THE 2X DRAWER IN A RACK (CONTD)

4. Position slide adjusting brackets as needed for rack depth. Mount right and left slides in rack. Position slides so 2X drawer rests on flat edge of slides.
5. Tighten screws holding adjusting brackets to slides and slides to rack.
6. Lift drawer and guide it into slide assemblies. Continue pushing inward until drawer is fully in rack. Drawer should not bind when sliding it in and out of rack.

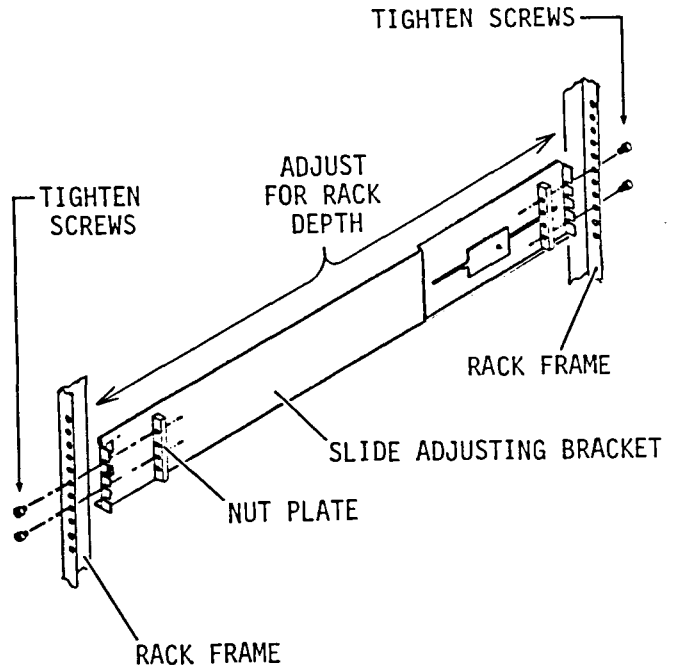

11F279A

If it is necessary to remove the drawer from the rack, slide it out to full extension. Press the drawer locking springs and remove the drawer from the rack.

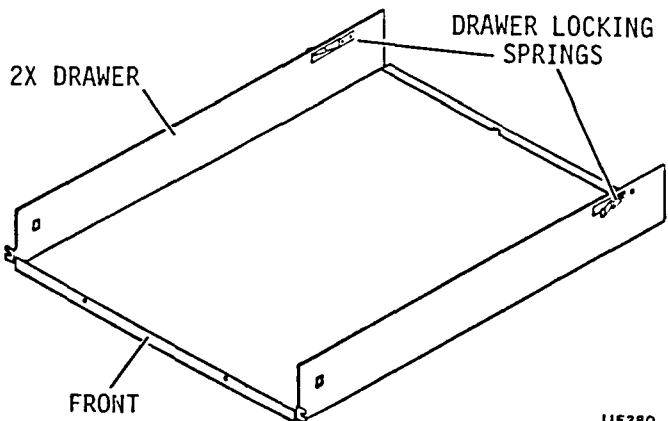

11F280

INSTALLING THE OPERATOR PANEL OR STATUS/CONTROL PANEL JUMPER CABLE

This procedure describes how to install an operator or status/control panel jumper cable as part of a new drive installation. Skip this procedure if your installation does not include an operator panel or status/control panel.

If you must add one to an existing installation, refer to Adding an Operator or Status/Control Panel at the end of this section.

1. Unpack operator panel or status/control panel kit.
2. Install longer of two metal cable clamps over exposed shielding on J13 end of jumper cable.
3. Install shorter of two metal cable clamps over exposed shielding on P13 end of jumper cable.

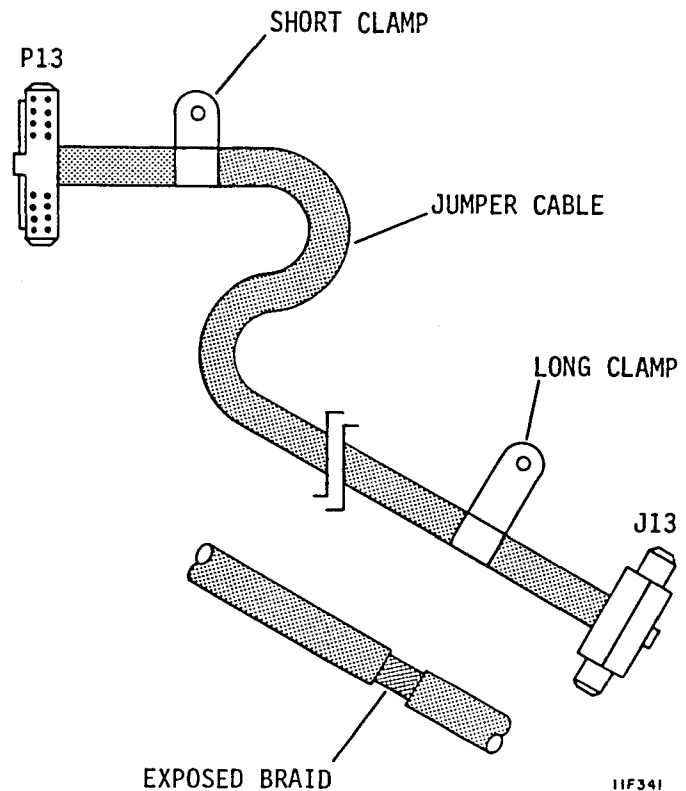

INSTALLING THE OPERATOR PANEL OR STATUS/CONTROL PANEL JUMPER CABLE (CONTD)

4. Attach cable clamp(s) at P13 end of jumper cable to inner drawer and route cable around left side.

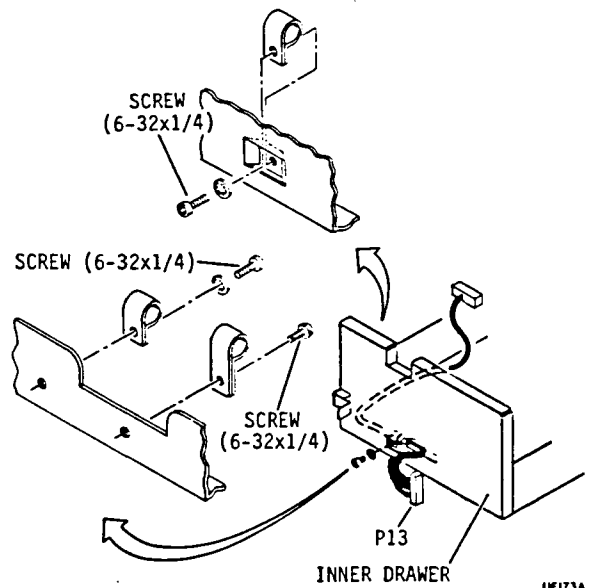

INSTALLING THE POWER SUPPLY IN THE INNER DRAWER

1. Remove heat shrink from 60 Hz power cord only, to expose shield in area shown.
2. Connect power cord to J1 on power supply, place power supply into inner drawer and secure with screws. Ensure cables are not pinched.
3. Place power cord behind tabs. Exposed shield on 60 Hz power cord must be behind tab as shown.
4. For 60 Hz power cords, place clamp over tab and shield. Bend tab to firmly secure clamp.
5. Connect dc power cable to J15 on power supply.
6. Secure ground strap to power supply. Ensure lockwasher is between strap and power supply.

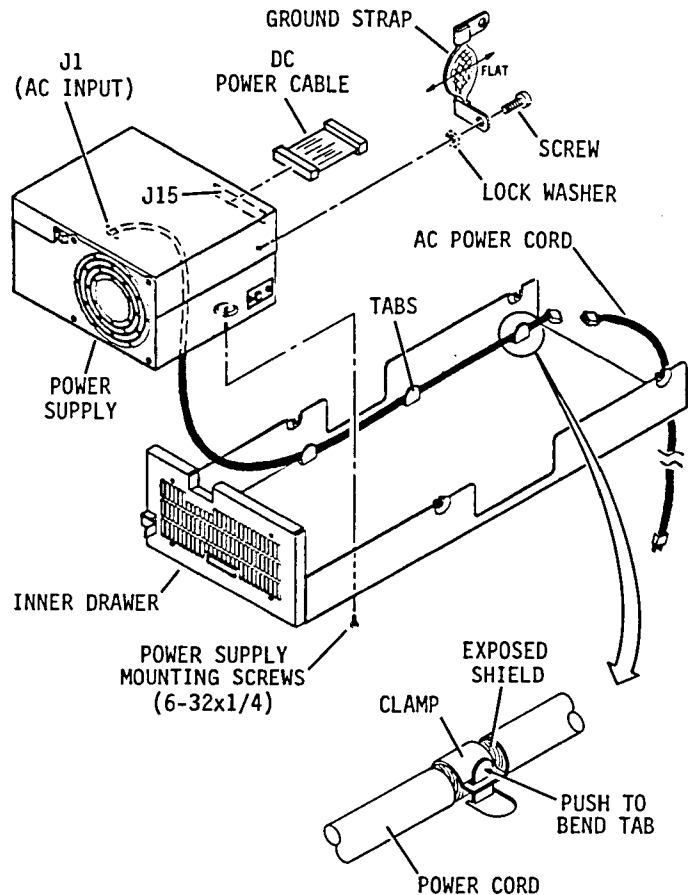

INSTALLING THE DRIVE IN THE INNER DRAWER

1. Loosely insert shock mount screws into shock mounts on drive.
2. With I/O connectors facing away from power supply, place drive into inner drawer so it rests on shock mount screws.
3. Lift power supply end of drive and connect dc power cable to J15A on drive. Connect operator panel or status/control panel jumper cable (if used) to J13 on control board.
4. Lower drive onto shock mount screws and tighten them.
5. Connect power supply ground strap from power supply to ground screw just above shock mount on drive. Ensure lockwasher is between drive and strap.
6. Some drives also have a ground strap at each shock mount. Connect these as shown.
7. If used, attach operator panel or status/control panel jumper cable clamp (long clamp) to hole just above shock mount. Ensure lockwasher is between clamp and drive.
8. Remove two top cover screws and install air baffle as shown.

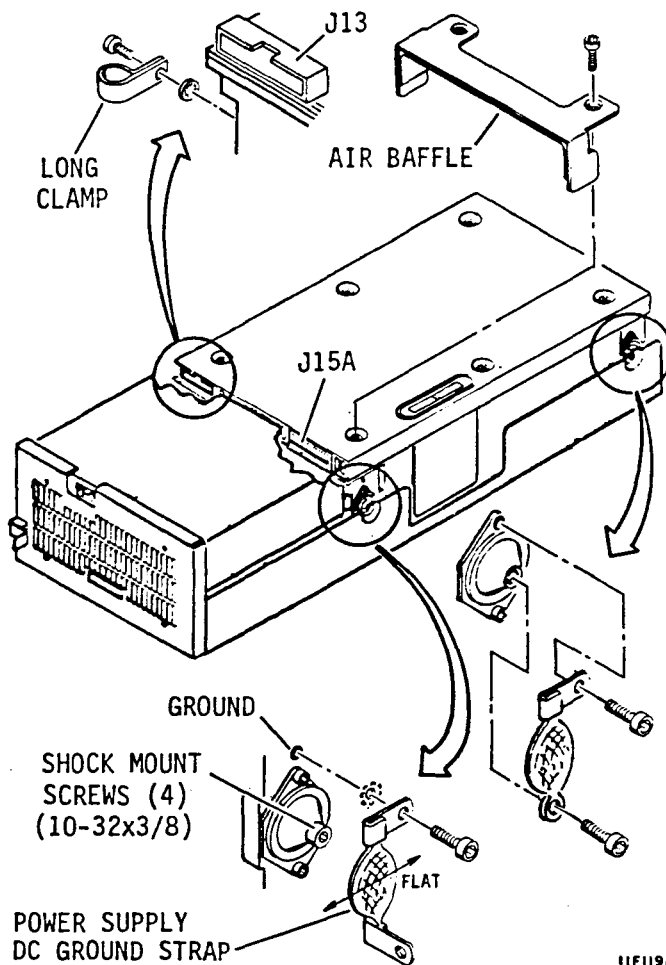

11F1198

INSTALLING THE INNER DRAWER INTO THE 2X DRAWER

1. Fully extend 2X drawer from rack.
2. Slide inner drawer into 2X drawer so rear edge of inner drawer is under lip on 2X drawer.
3. Secure inner drawer into 2X drawer with locking screw.
4. Repeat steps 2 and 3 for other drive.
5. Push 2X drawer to closed position in rack.
6. Connect one end of ac power cable to short ac power cable. Connect the other end to site power.

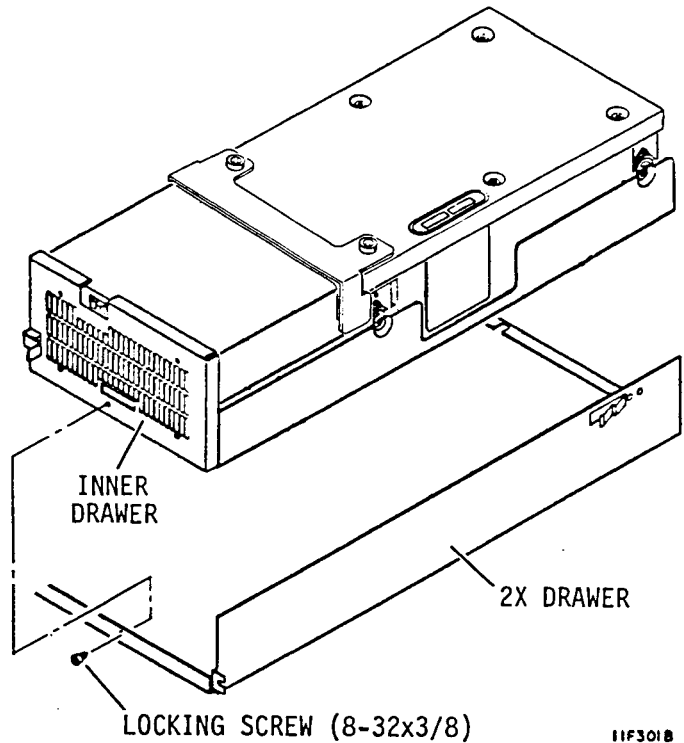

11F301B

INSTALLING THE FRONT PANEL

Perform this procedure only if an optional operator panel or status/control panel is NOT being installed.

1. Position front panel on drive. Turn front panel 180° if drive is placed at the right side of 2X drawer.
2. Align top edge of front panel with top edge of inner drawer.
3. Ensure front panel is positioned for best alignment and appearance and secure it with four screws.
4. Install air filter.

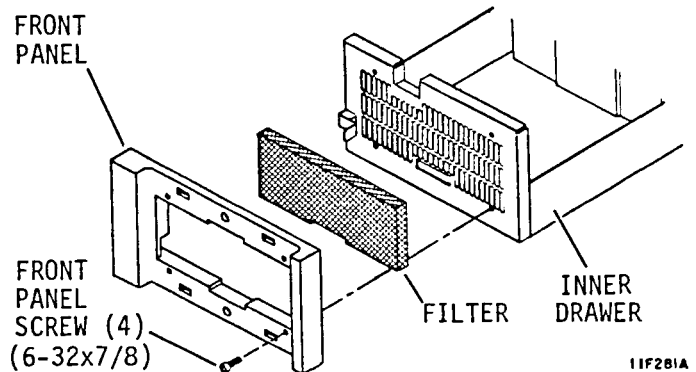

5. Remove adhesive backing from filler plate and attach it to front panel insert.
6. Install front panel insert.

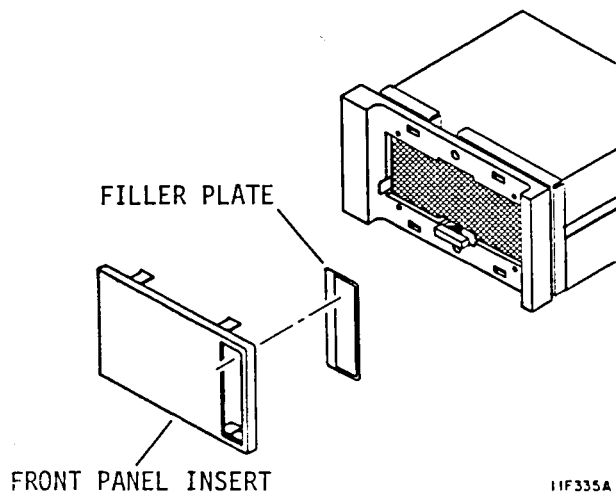

INSTALLING THE STATUS/CONTROL PANEL

Use this procedure to complete the mounting of the optional status/control panel. The jumper cable that connects the status/control panel to the control board should already be installed.

1. Orient front panel so wide edge faces left on left drive and right on right drive.
2. Center screw holes in front panel on screw holes in inner drawer.
3. Insert two screws on right side of front panel.
4. Install air filter.
5. Connect P13 on jumper cable to P13 on status/control panel.
6. Align status/control panel to front panel and secure with screws.
7. Remove protective film from status/control panel.
8. Install front panel insert.

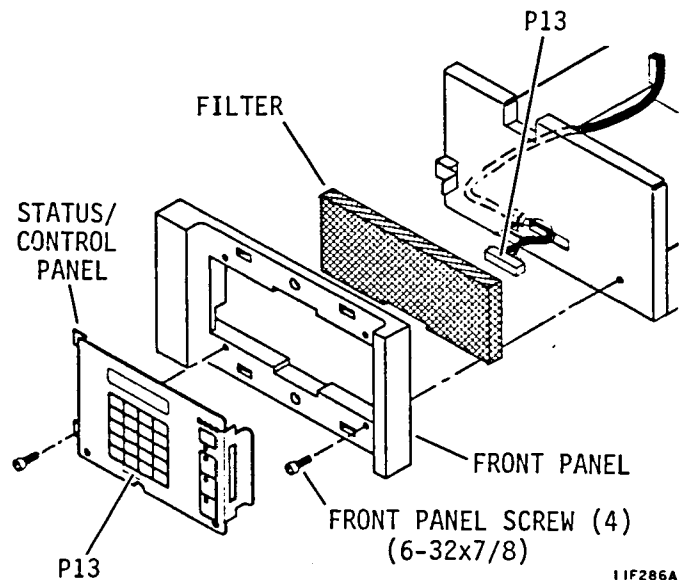

INSTALLING THE OPERATOR PANEL

Use this procedure to complete the mounting of an optional operator panel. The jumper cable that connects the operator panel to the control board should already be installed.

1. Orient front panel so wide edge faces left on left drive and right on right drive.
2. Center screw holes in front panel on screw holes in inner drawer.
3. Insert two screws on left side of front panel.
4. Install air filter.
5. Remove screws holding operator panel to shield.
6. Align shield and front panel and secure both to inner drawer with screws.
7. Connect P13 on jumper cable to P13 on operator panel.
8. Position operator panel on shield and secure with screws.
9. Install front panel insert.

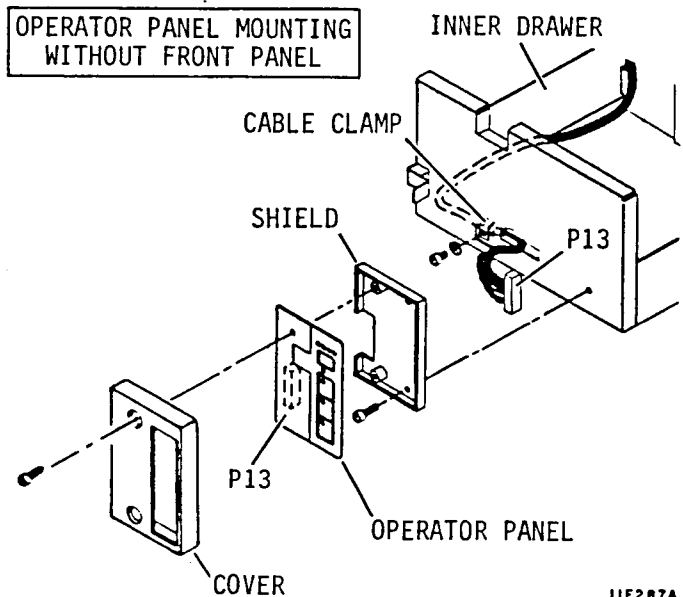
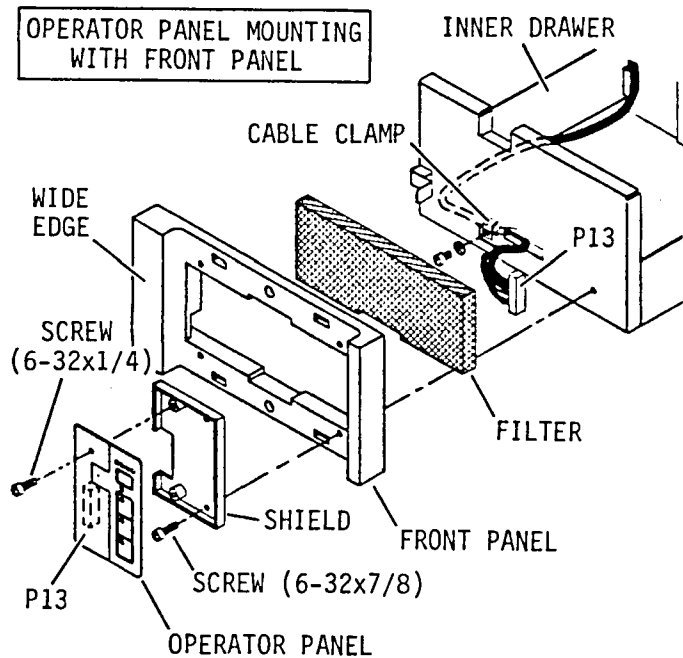

11F207A

OTHER WAYS TO MOUNT THE DRIVE

The following requirements must be met if the drive is mounted in other than a 2X drawer:

- Support the drive by its shock mounts, either horizontally or vertically.
- Allow adequate clearance between the drive and any surfaces near it.
- Ensure the mounting design allows adequate ventilation of the drive and power supply.
- Install the optional fan kit if the power supply is mounted remotely from the drive.

When the power supply mounting is remote from the drive, a shielded dc power cable is recommended. One end of the cable connects to J15 on the power supply, and the trailing ground lead on that end connects to the ac ground terminal. The other end of the cable connects to J15(B) on the drive. The trailing ground lead on that end connects to the dc ground screw at the back of the drive.

When installing a remote power supply for 60 Hz operation, we recommend that you use a shielded ac power cable and connect the shield to the power supply case. You must remove heat shrink from the short ac power cable to expose the shield. Then install a cable clamp on the shield and attach it to the ac ground screw on the power supply. Finally, connect one end of the ac power cable to the short ac power cable and the other end to site power.

When the power supply is mounted remotely, an optional auxiliary fan and rear panel may be installed to provide air circulation for the drive. The fan kit has the fan mounted so the airflow arrow (on the body of the fan) will point toward the drive. This blows cooling air through the drive and is the preferred method. If, however, the installation requires it, the fan may be reversed so that the airflow arrow points away from the drive. This draws warm air out of the drive.

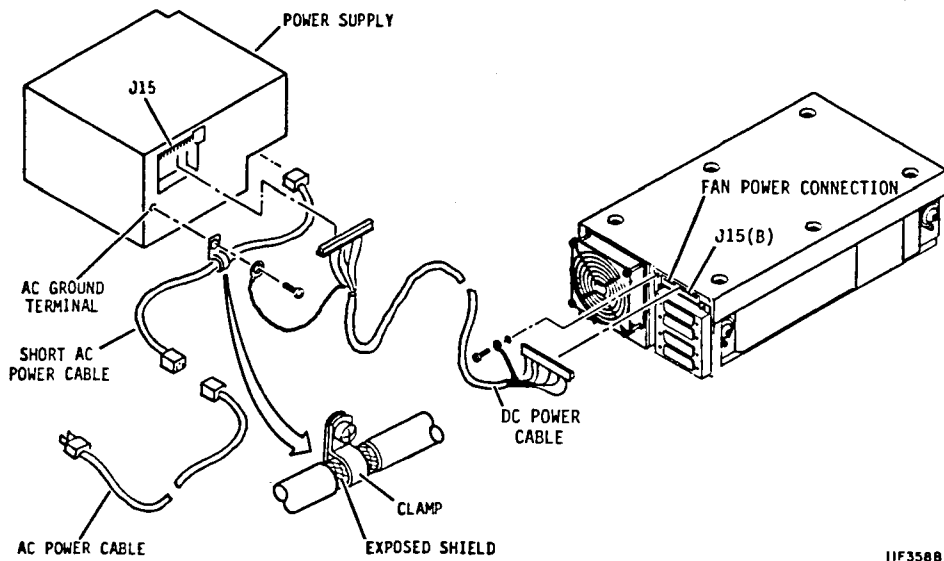

IIF3588

CONNECTING STAR SYSTEM I/O CABLES

NOTE

You can use the star cabling scheme only if the controller has one unused I/O connector for each drive in the system.

1. Route an I/O cable from controller to each drive in system.
2. Connect controller end (port A) of each I/O cable to appropriate I/O connector for each drive.
3. Connect drive end of each I/O cable to J4-1 on each drive.

NOTE

Use the enable/disable switch on I/O board to disable unused ports.

4. Install terminator on I/O connector J3-1 on each drive.
5. If this is a dual port system, repeat steps 1 through 4 for second controller (port B). I/O cables connect to J4-2 on each drive and terminator is installed on J3-2.

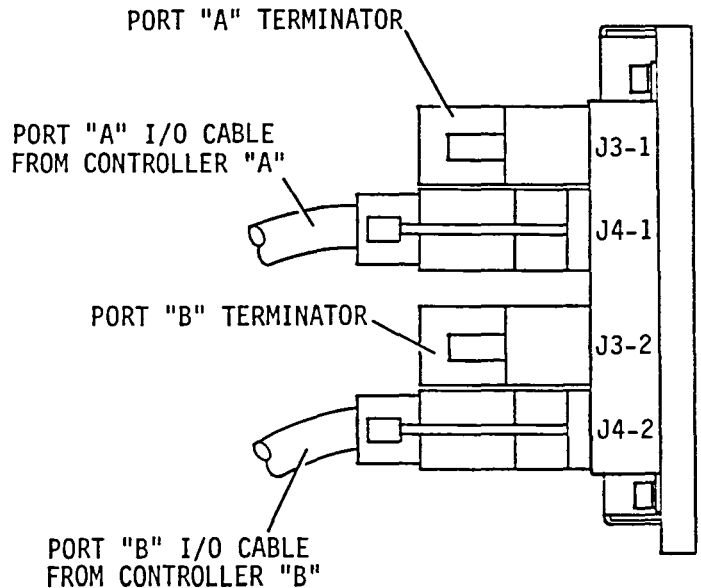

11F359A

CONNECTING DAISY CHAIN SYSTEM I/O CABLES

A daisy chain I/O scheme needs only one I/O connector on the controller.

1. Route one I/O cable from controller to first drive in the string.
2. Connect controller end of I/O cable to port A drive I/O connector on controller.
3. Connect drive end of I/O cable to J04-1 on first drive.
4. Continue connecting drives by routing I/O cable between J03-1 on drive and J04-1 on next drive in string.

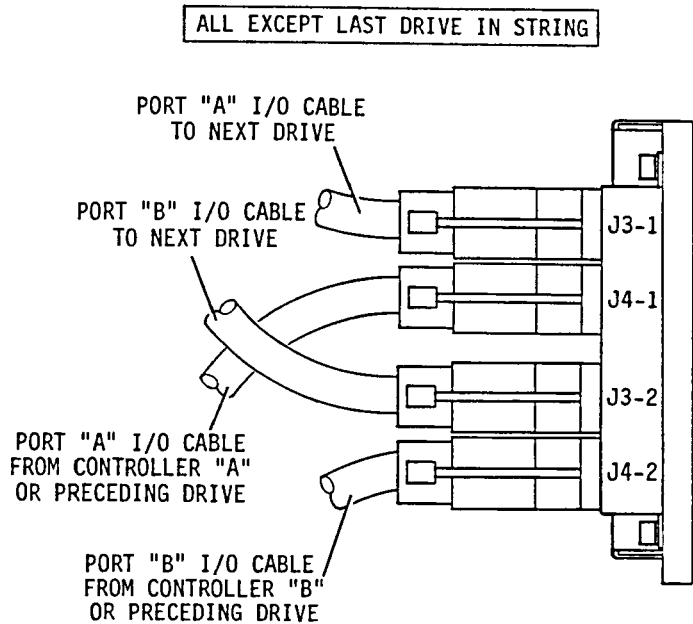

NOTE

Do not install a terminator on an unused port (i.e., if an I/O cable is not connected to J04-1 or J04-2). Disable an unused port with the port enable/disable switch on I/O board.

5. Install a terminator on J03-1 on the last drive in the string.
6. If this is a dual port system, repeat steps 1 through 5 for second controller (port B). I/O cables connect to J04-2 on each drive and terminator installs on J03-2 on last drive in string.

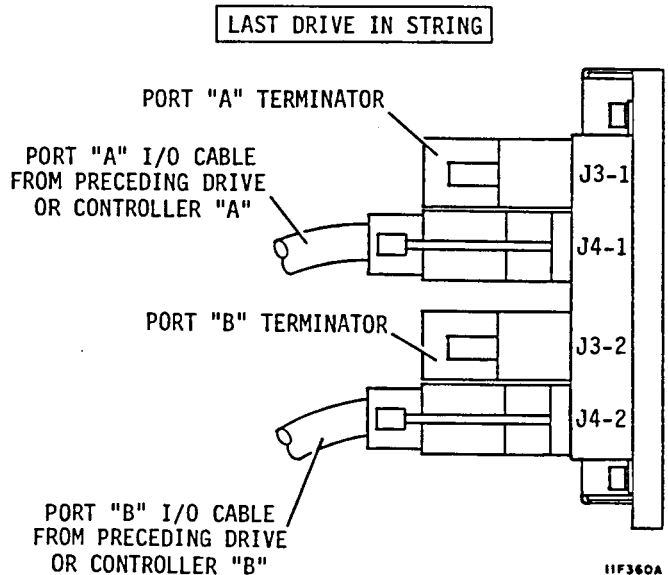

SPINDLE SYNC CABLE CONNECTIONS

Typical spindle sync cable connections are shown in the illustration at the right. Spindle sync cable connections are needed only if the feature is used.

A spindle sync terminator must be installed on connector J50 of each drive if the feature is not used. See Spindle Synchronization Information in this section for additional information about this feature.

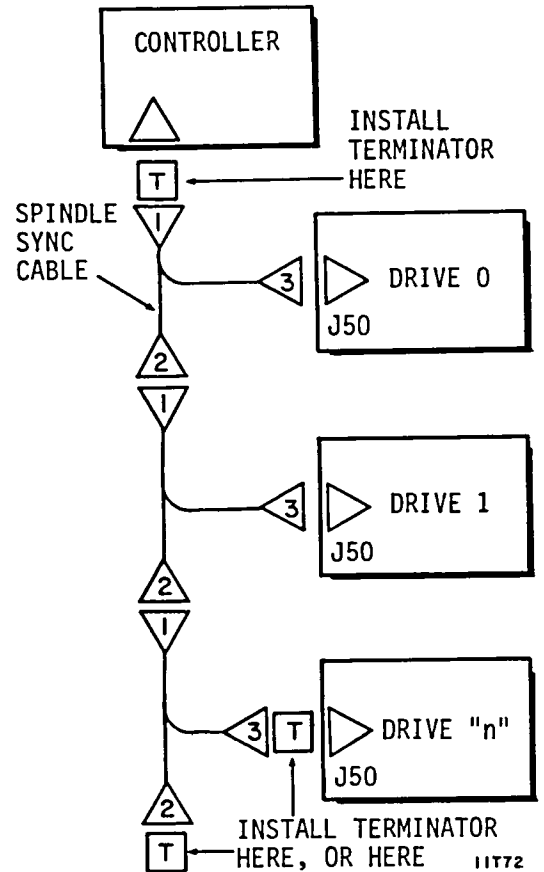
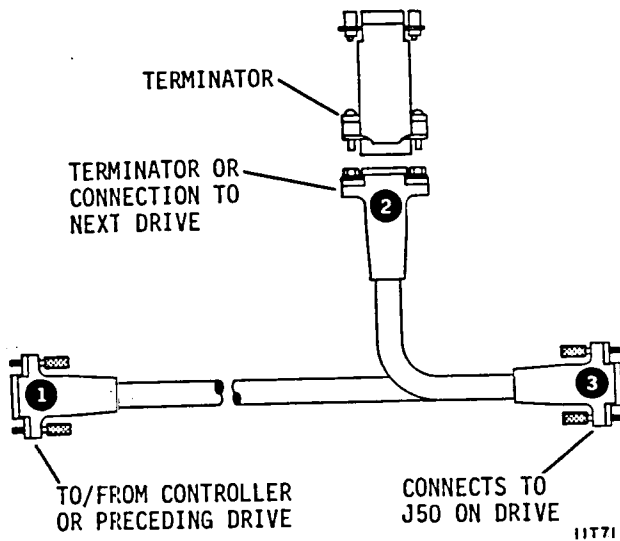

CONNECTING A STAR SYSTEM GROUND

Grounding the system through the power cables and I/O cables is usually sufficient to protect against noise and emissions. If additional protection is required, the following instructions are recommended for grounding the system. In this system, the earth ground connection on the controller is connected to an earth ground and to each drive in the system.

1. Allowing for extension of drives, cut ground straps to length needed to connect each drive to system ground point on controller. Cut One more strap to connect ground on controller to earth ground.
2. Crimp and solder terminal lugs to both ends of each ground strap.
3. Remove screw and lockwasher from ground point (DC GND) on each drive.
4. With lockwasher under ground strap, attach a ground strap to DC GND point on each drive.
5. Attach controller and all drive ground straps to system ground point on controller.
6. Connect other end of controller ground strap to earth ground.

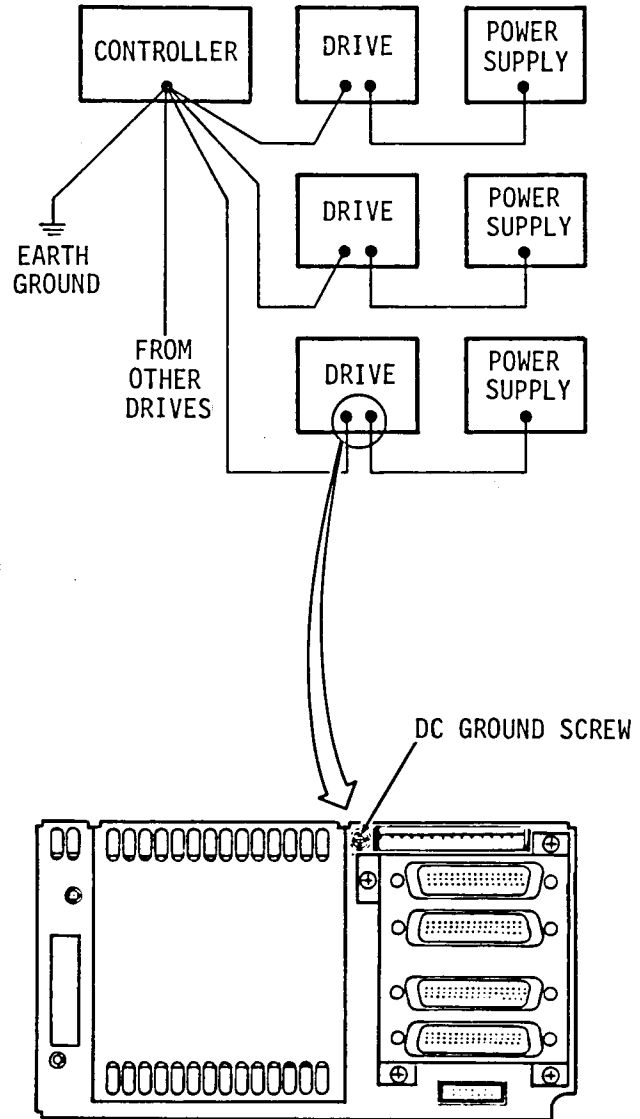

11F361A

CONNECTING A DAISY CHAIN SYSTEM GROUND

Grounding the system through the power cables and I/O cables is usually sufficient to protect against noise and emissions. If additional protection is required, the following instructions are recommended for grounding the system. In this system, the earth ground connection on the controller is connected to an earth ground and to the DC GND point on the first drive in the string. Other ground straps connect between the DC GND point on the first and second drive, second and third, etc.

1. Allowing sufficient length for drive extension, cut ground straps to length for use:

- between each drive
- between the first drive and controller
- between controller and earth ground

2. Crimp and solder terminal lugs to both ends of each strap.
3. Remove screw and lockwasher from DC GND point on each drive.
4. With lockwasher under ground straps, attach them to DC GND point on each drive.
5. Attach earth ground strap and ground strap from first drive, to system ground point on controller.
6. Connect other end of controller ground strap to earth ground.

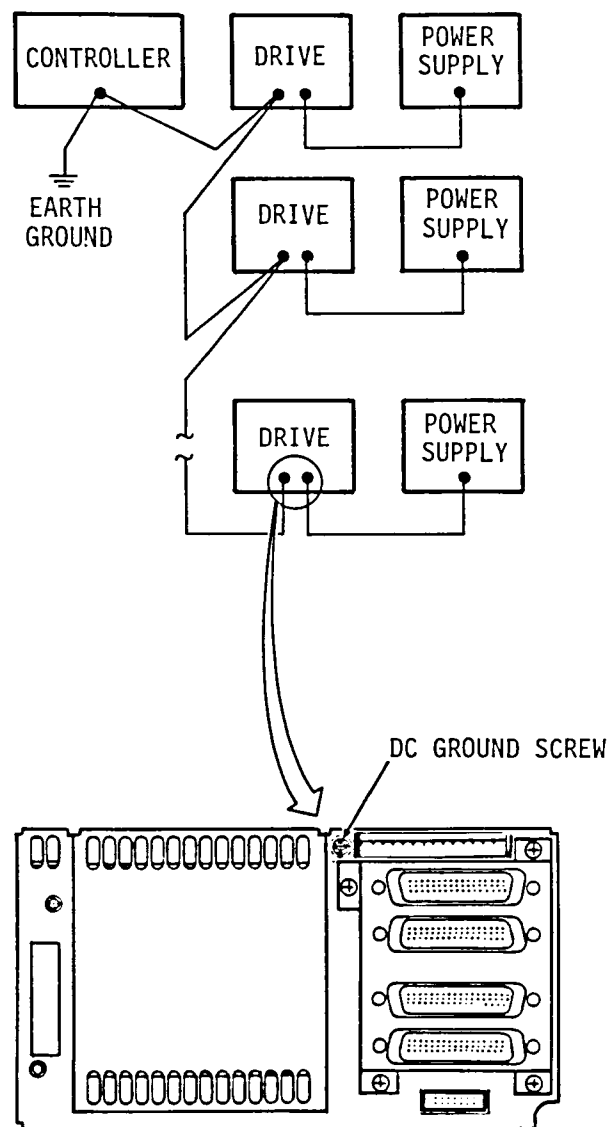

11F362A

PROVIDING A SAFETY GROUND

A safety ground must be provided by the site ac power system. The green wire (or green wire with yellow stripe) in the drive power cord provides the safety ground connection between the power supply and the site ac power system. The site ac power system must provide the safety ground to earth ground connection.

All site ac power connection points, including convenience outlets for test equipment, must be maintained at the same safety ground potential.

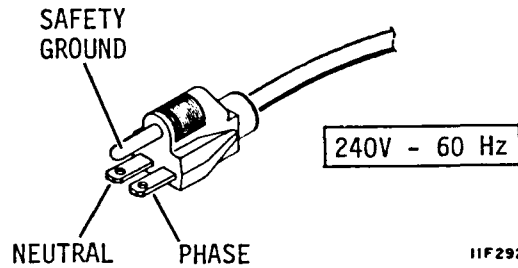
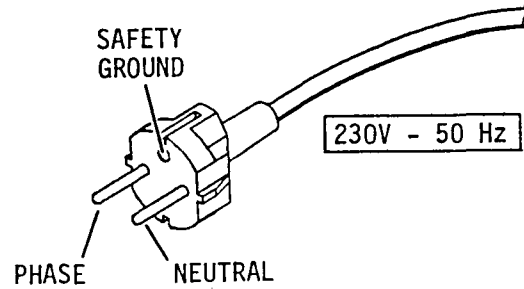
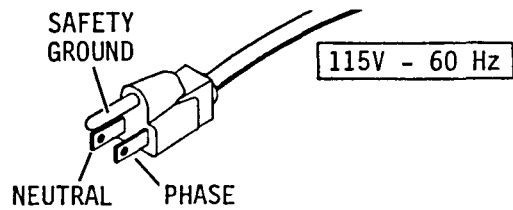

11F292A

HOW TO OPERATE DIP SWITCHES

Two groups of small switches (called DIP switches) allow tailoring the drive to your exact needs. One set of DIP switches is found on the I/O board. You reach them through a hole at the left side of the rear panel. The other set is found on the control board. They are reached through holes in the drive top cover.

You may encounter two types of switches. Rocker switches are actuated by pressing one end of the actuator or the other (rocking it) to turn the switch on (closed) or off (open). Slide switches are turned on or off by sliding the actuator one way or the other. Use a slender ball point pen, a straightened paper clip, or any similar object to change the switch settings. DO NOT use a lead pencil point as it may break off and lodge in the switch, or cause the switch to malfunction.

The switches are mounted in a plastic case and are usually numbered. Other labels may appear next to the switches on the circuit board, or a label may appear at the sides of the access hole in the drive. The position of the labels may not always coincide with the switch setting that enables the function. Always use the table of switch settings to properly set the switches for your needs. A switch is considered closed in the on position and open in the off position.

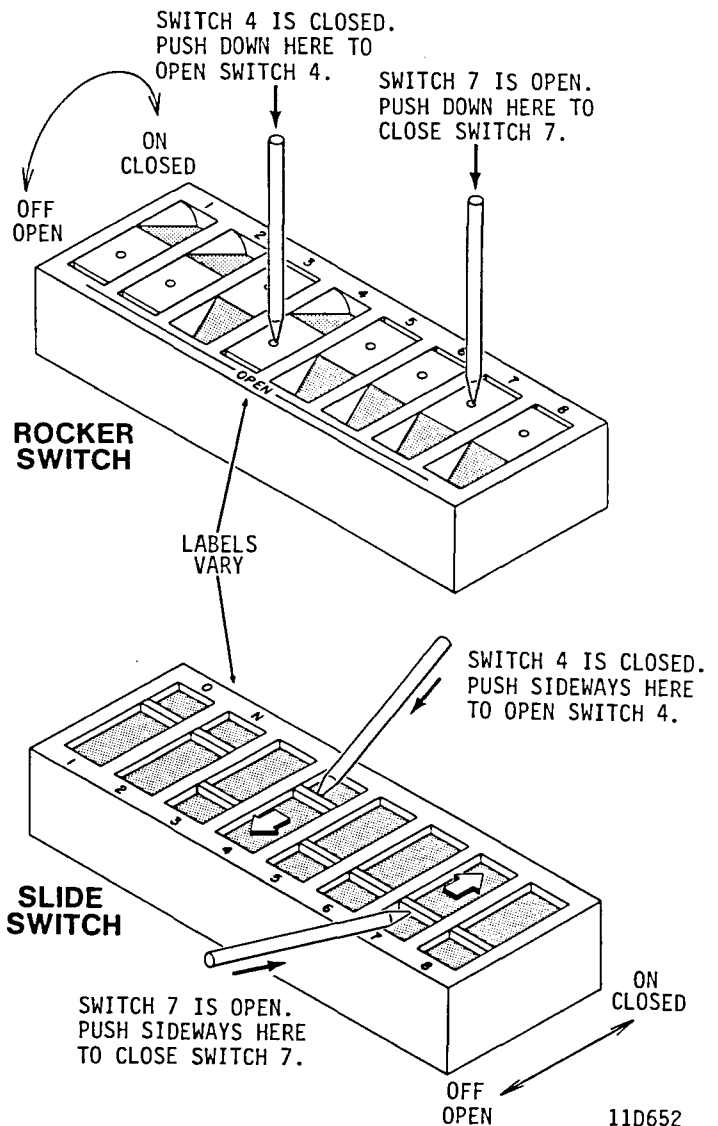

SETTING THE I/O BOARD SWITCHES

NOTE

The Enable Master Sync switch is used only on PA8Y2A drives with newer I/O boards. PA8Y2A drives with older I/O boards have an Enable Master Sync jumper as shown under the topic Enable Master Sync Switch (or Jumper).

If equipments other than PA8Y2A have this switch, it is not functional.

The switches on the I/O board are accessible through a hole in the lower left side of the rear panel. Use the table on the next page to determine if the switch settings must be changed.

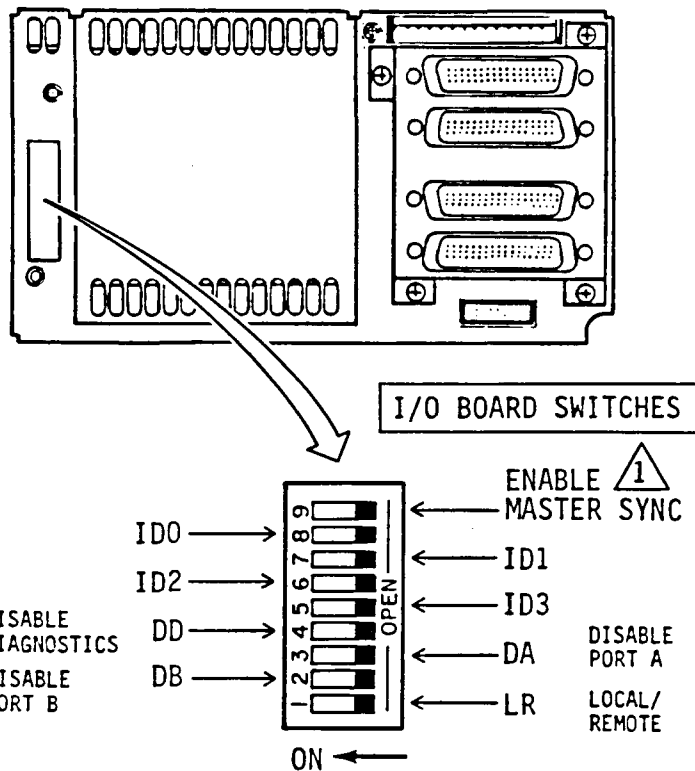

NOTE:

 NOT USED ON ALL DRIVES.

ON = CLOSED
OFF = OPEN

IIF363C

SETTING THE I/O BOARD SWITCHES (CONTD)

Switch	Setting	Description
L/R (Local/Remote)	Local (off/open)	Disc spin-up starts when dc power is applied, or when the START switch is pressed if the drive has an optional operator or status/control panel.
	Remote (on/closed)	Factory set to this position. Spin-up command from interface is required to start drive.
DA - DB Port Disable (A or B)	Enable (off/open)	Enables the port for normal operation. Factory set to this position.
	Disable (on/closed)	Disables use of the port.
DD Disable R/W Diagnostics	Enable (off/open)	Enables internal diagnostic program to perform read and write operations. Factory set to this position.
	Disable (on/closed)	Prevents internal diagnostic program from doing read and write operations
Enable Master Sync	Enable (on/closed)	Establishes drive as a master for spindle sync.
	Disable (off/open)	Factory set to this position. Drive is slave unless controller designates it as master. See Spindle Sync Information (next topic).

Continued

SETTING THE I/O BOARD SWITCHES (CONTD)

Switch	Setting	Description
<p style="text-align: center;">ID0 - ID3 (ID Microcode)</p>		<p>These switches assign a unique device configuration code.</p>
	<p>ID0, ID2, ID3 off/open, ID1 on/closed</p>	<p>850 MB drives without RPS extension parameters.</p>
	<p>ID0, ID2 off/ open, ID1, ID3 on/closed</p>	<p>850 MB drives with RPS extension parameters.</p>
	<p>ID1 off/open, ID0, ID2, ID3 on/closed</p>	<p>1153 MB drives without RPS extension parameters.</p>
	<p>ID1, ID3 off/ open, ID0, ID2 on/closed</p>	<p>1153 MB drives with RPS extension parameters.</p>
	<p>ID2, ID3 off/ open, ID0, ID1 on/closed</p>	<p>1230 MB drives without RPS extension parameters.</p>
<p>ID2 off/open, ID0, ID1, ID3 on/closed</p>	<p>1230 MB drives with RPS extension parameters.</p>	

SPINDLE SYNCHRONIZATION INFORMATION

NOTE

This topic applies to PA8Y2A drives only.

PA8Y2A series code 01 drives without ECO DJ40366 installed cannot supply the reference signal discussed in the following paragraphs. It must be supplied by an external source (the controller).

PA8Y2A drives have the capability of synchronizing their spindles to an external reference signal applied at connector J50. If the external reference is not present, the drives operate in a non-synchronous mode. The reference signal can be supplied by one of the drives or by an external source (the controller). The tolerance of the spindle lock is ± 50 usec, and is achieved within 60 seconds after:

- The spindle achieves full speed (3600 r/min during a motor start routine, provided a reference signal is present.
- A reference signal is present that was not previously detected, and the spindle is operating at its specified speed.

THE ENABLE MASTER SYNC SWITCH (OR JUMPER)

NOTE

This topic applies to PA8Y2A drives only. If other drives have this switch (or jumper), it is not functional.

PA8Y2A drives have an Enable Master Sync switch (or jumper) on the I/O board that allows the drive to be designated a master or slave.

The Enable Master Sync switch is one of the DIP switches located above connector J50 on the I/O board. The Enable Master Sync jumper is just to the right of the spindle sync connector J50 on the I/O board.

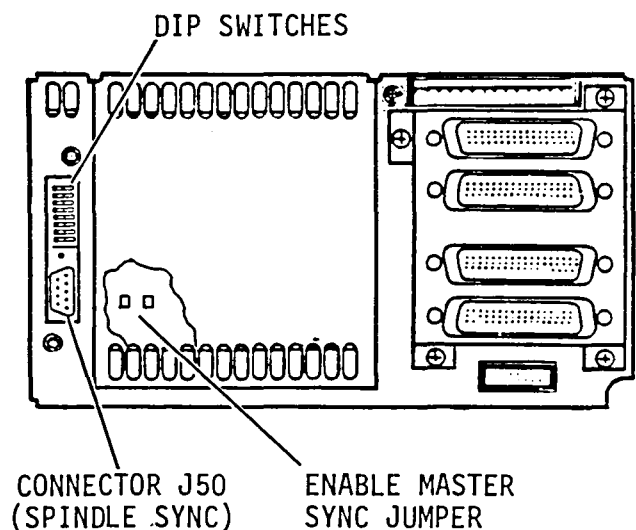

11F77B

With the Enable Master Sync switch set in the On position (or the Enable Master Sync jumper in place), the drive is designated a master and it provides the sync reference signal to all other drives and controllers connected in the daisy chain. The Enable Master Sync switch must be set in the Off position (or the Enable Master Sync jumper must be removed) on all other drives in the string.

With the Enable Master Sync switch set in the Off position (or the Enable Master Sync jumper removed), the reference signal must be provided by an external source.

HOW TO ACCESS THE ENABLE MASTER SYNC JUMPER

1. Remove the four screws securing the connector adapter to the back of the drive.
2. Remove the connector adapter.
3. Remove the standoffs securing connector J50 to rear panel.
4. Remove the four screws that secure the rear panel to the drive.
5. Remove the rear panel from the drive. The Enable Master Sync jumper is located just to the right of the connector J50.
6. After positioning the jumper as required, reverse the procedure to install the back cover and connector adapter.

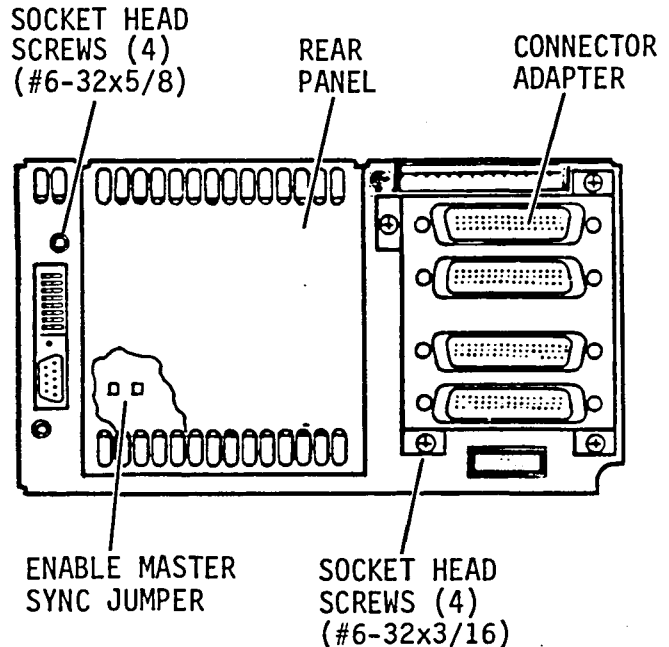

11F116B

DESIGNATING A MASTER USING THE ENABLE MASTER SYNC SWITCH

The Enable Master Sync switch is set in the Off position when the drive is shipped from the factory. Set the switch in the On position to designate that drive as a master. It will then provide the spindle sync reference signal to all drives and controllers in the string. Set the switch in the Off position on all other drives in the string.

The spindles will synchronize to an external source if the Enable Master Sync switch is set in the Off position on all drives and the cable is connected to an external reference.

DESIGNATING A MASTER USING THE ENABLE MASTER SYNC JUMPER :

The Enable Master Sync jumper is removed when the drive is shipped from the factory. To reach the Enable Master Sync jumper, remove the I/O adapter and back cover. Install the jumper (connect the two pins) to designate that drive as a master. It will then provide the spindle sync reference signal to all drives and controllers in the string. Remove the Enable Master Sync jumper on all other drives in the string.

The spindles will synchronize to an external source if the Enable Master Sync jumper is disconnected on all drives and the cable is connected to an external reference.

DESIGNATING A MASTER USING BUS CONTROLS

A drive can be designated a master using Bus Controls issued on the IPI-2 interface, rather than using the Enable Master Sync switch (or jumper) on the I/O board. Bus Control 'Load Drive Function' (01) with function code 'Enable Master Sync' (1F) causes the selected drive to become a master. As such, it provides the spindle sync reference signal to the other drives in the string. If the 'Enable Master Sync' function is presented to a drive that is designated as a master using the Enable Master Sync switch (or jumper), it rejects the 'Enable Master Sync' function and provides Slave Ending status 'Bus Control Exception'. This sets bit 5 of octet 0 in Status Response 'Bus Control Exception', and bit 6 of octet 2 in Status Response 'Invalid Parameter'.

A Bus Control 'Load Drive Function' (01) with 'Disable Master Sync' function code (2E) causes the selected drive to cease being a master. It must obtain the sync reference signal from another source. If the drive has been designated a master using the Enable Master Sync switch (or jumper), it rejects the 'Disable Master Sync' function and provides Slave Ending status 'Bus Control Exception'. This condition sets bit 5 of octet 0 in Status Response 'Bus Control Exception' and bit 6 of octet 2 in Status Response 'Invalid Parameter'.

SETTING THE CONTROL BOARD SWITCHES

There are three types of control boards that have been used with these drives. The visual differences are the LED locations, the jumper locations, and whether or not sector switches are on the board. Refer to the accompanying illustration to determine which control board your drive uses.

The switches on the control board are reached by removing the plastic cover from the hole in the drive top cover. Switch settings are described in the table on the next page.

Following the switch settings descriptions are descriptions of the control board indicators.

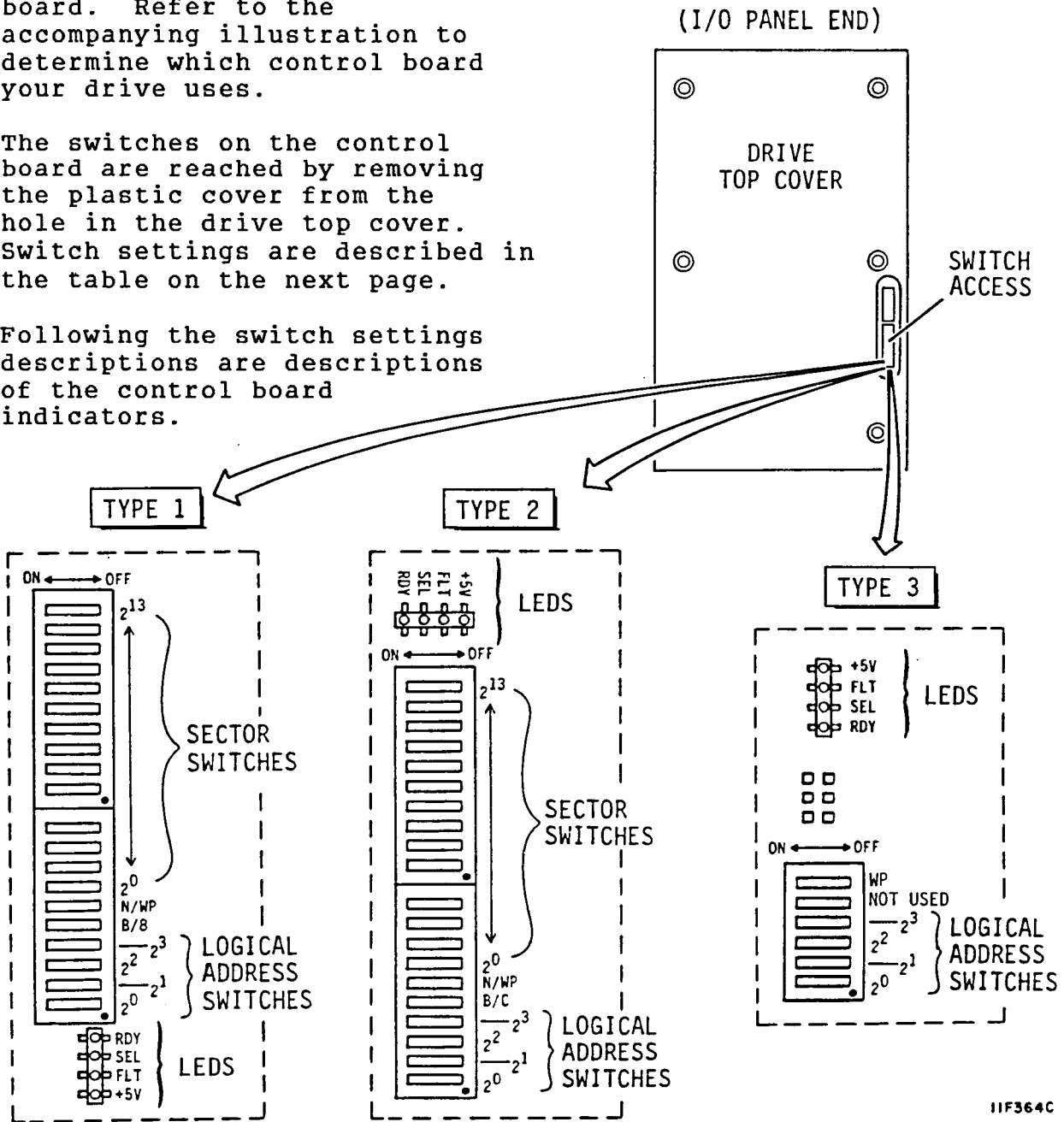

SETTING THE CONTROL BOARD SWITCHES (CONTD)

Switch	Setting	Description																																													
Sector Switches (Type 1 and 2 boards only)		These switches are not used. Changing the settings has no effect on drive operation.																																													
Logical Address		If no operator panel or status/control panel is used, select the logical address from the table below and then set switches $2^0 - 2^3$ as shown. The switches are factory set for address 0 (all on/closed).																																													
		<table border="1"> <thead> <tr> <th>Logical Address</th> <th>2^3</th> <th>2^2</th> <th>2^1</th> <th>2^0</th> </tr> </thead> <tbody> <tr><td>0</td><td>ON</td><td>ON</td><td>ON</td><td>ON</td></tr> <tr><td>1</td><td>ON</td><td>ON</td><td>ON</td><td>OFF</td></tr> <tr><td>2</td><td>ON</td><td>ON</td><td>OFF</td><td>ON</td></tr> <tr><td>3</td><td>ON</td><td>ON</td><td>OFF</td><td>OFF</td></tr> <tr><td>4</td><td>ON</td><td>OFF</td><td>ON</td><td>ON</td></tr> <tr><td>5</td><td>ON</td><td>OFF</td><td>ON</td><td>OFF</td></tr> <tr><td>6</td><td>ON</td><td>OFF</td><td>OFF</td><td>ON</td></tr> <tr><td>7</td><td>ON</td><td>OFF</td><td>OFF</td><td>OFF</td></tr> </tbody> </table>	Logical Address	2^3	2^2	2^1	2^0	0	ON	ON	ON	ON	1	ON	ON	ON	OFF	2	ON	ON	OFF	ON	3	ON	ON	OFF	OFF	4	ON	OFF	ON	ON	5	ON	OFF	ON	OFF	6	ON	OFF	OFF	ON	7	ON	OFF	OFF	OFF
		Logical Address	2^3	2^2	2^1	2^0																																									
0	ON	ON	ON	ON																																											
1	ON	ON	ON	OFF																																											
2	ON	ON	OFF	ON																																											
3	ON	ON	OFF	OFF																																											
4	ON	OFF	ON	ON																																											
5	ON	OFF	ON	OFF																																											
6	ON	OFF	OFF	ON																																											
7	ON	OFF	OFF	OFF																																											
If an operator panel or status/control panel is used, these switches are ignored. Select the logical address as described in section 3.																																															
B/8 (Type 1 boards) B/C (Type 2 boards)		This switch is not used. Changing the setting has no effect on drive operation.																																													
WP/N	WP (off) N (on)	Write Protect (prevents writing) Normal (allows writing)																																													
Switch On = Closed, Switch Off = Open																																															

CONTROL BOARD INDICATORS

Indicator	Function
Maintenance LEDs	Provide indications of drive status when no operator panel or status/control panel is available.
+5 V	Indicates presence of +5 V.
SEL	Indicates that drive is selected by a controller.
RDY	Indicates that the drive is ready (spindle power on is complete, heads are loaded, and no fault exists).
FLT	Indicates that a fault exists within the drive.

SETTING THE CONTROL BOARD JUMPERS

Each of the three types of control boards shown below have jumpers that control operation of some special features. Setting of these jumpers is described in the table on the next page, and in the Sweep Cycle Information that follows it. Review this information carefully to determine if jumper settings must be changed.

If you need to make jumper position changes on a type 1 board where the jumpers are not accessible through the access hole in the top cover, you must remove the six screws and lift the cover off the drive. The jumpers on type 2 and type 3 boards are accessible through the access hole in the top cover.

A jumper is connected when it connects the two pins, and is disconnected when it is removed or left connected to only one of the two pins. Install the top cover (type 1 boards) or the plastic hole cover when finished setting jumpers.

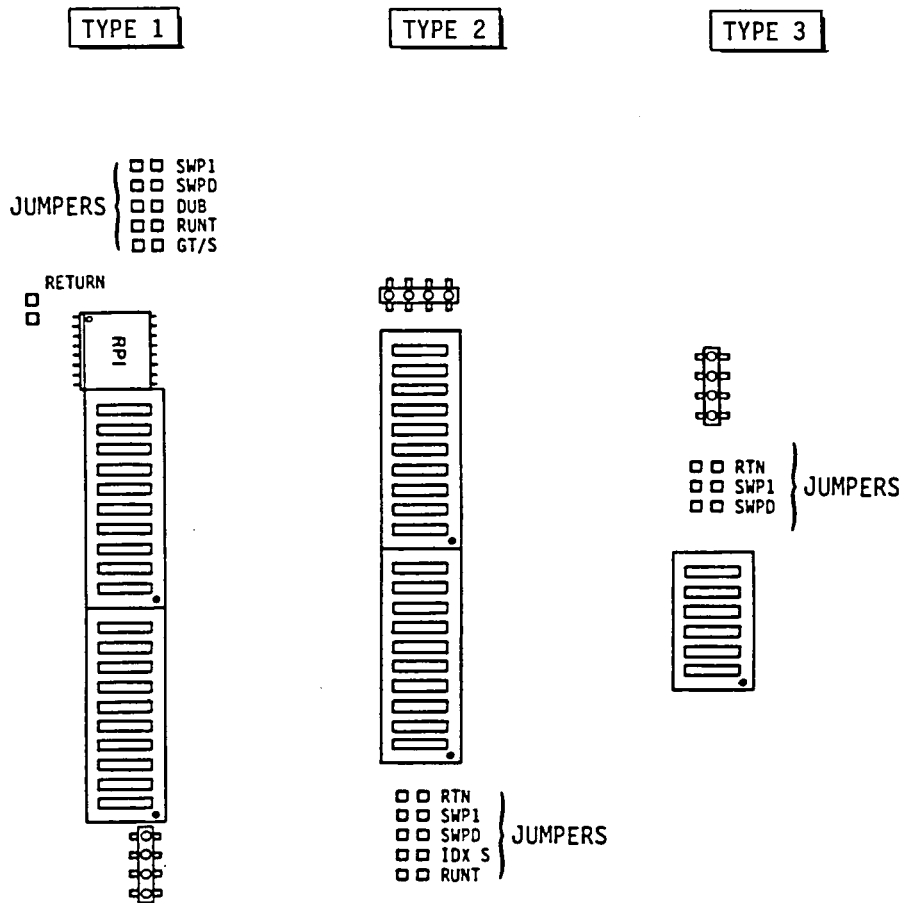

11F378A

SETTING THE CONTROL BOARD JUMPERS (CONTD)

Jumper	Position	Description
RUNT (see Note 1)	Connected	Suppresses runt sector pulses.
	Disconnected	Allows runt sector pulses. The drive is shipped with this jumper disconnected.
DUB (see Note 2)	Connected	The drive is shipped with this jumper connected. Do not change this factory setting.
GT/S (see Note 2)	Disconnected	The drive is shipped with this jumper disconnected. Do not change this factory setting.
SWP1 (see Note 3)	Connected	Disables the option for sweep cycle only on seeks. This position should not be used.
	Disconnected	Enables the option for sweep cycle only on seeks.
SWPD (see Note 3)	Connected	Disables sweep cycle operation.
	Disconnected	Enables sweep cycle operation. The drive is shipped with this jumper disconnected.
RTN/Return (not labelled on type 1 boards)	Disconnected	Disables the option to return heads to their original position following a sweep segment. Do not change this factory setting.
	Connected	Enables the option to return heads to their original position following a sweep segment only if drive was selected during last 12 minutes. If drive was not selected during last 12 minutes, the heads stay on the last track the sweep segment moved them to.

Continued

SETTING THE CONTROL BOARD JUMPERS (CONTD)

Jumper	Position	Description
IDX S (see Note 4)	Disconnected	The drive is shipped with this jumper disconnected. Do not change this factory setting.
	Connected	This setting must not be used.
Note 1: Found only on type 1 and type 2 boards. Note 2: Found only on type 1 boards. Note 3: See Sweep Cycle Information on next page. Note 4: Found only on type 2 boards.		

SWEEP CYCLE INFORMATION

The sweep cycle is a feature that periodically moves the heads to different locations on the discs during periods when the drive is idle. Some advantages of using a sweep cycle are:

- It enhances drive reliability. You are encouraged to use the drive sweep cycle or a sweep cycle that is controlled by the system or subsystem. Consult with a systems analyst before making this choice.
- The sweep cycle routine only takes about 11 seconds in a 13 hour period. This means the drive is still available to the system more than 99% of the time.
- You may disable the sweep cycle without affecting the specified Mean Time Between Failures (MTBF) or warranty agreements.

WHICH DRIVES HAVE THE SWEEP CYCLE FEATURE

- Drives were shipped with the sweep cycle feature disabled (SWPD jumper is connected) because of I/O constraints. Do not disconnect the SWPD jumper in an attempt to enable the sweep cycle feature on these drives. You can use a sweep cycle that is controlled by the system or subsystem.
- Drives that have the sweep cycle feature fully implemented will ship from the factory with the feature enabled (SWPD jumper disconnected). You may disable the sweep cycle feature on these drives, or continue to use a sweep cycle controlled by the system or subsystem if desired.

HOW TO ENABLE OR DISABLE THE SWEEP CYCLE FEATURE

The three sweep cycle jumpers (SWPD, SWP1, and RTN) control the sweep cycle feature. All three jumpers are disconnected to enable the sweep cycle feature when the drive ships from the factory. To ensure proper drive operation when the sweep cycle feature is used, these jumper settings must not be changed.

To disable the sweep cycle feature, connect the SWPD jumper. Leave the SWP1 and RTN jumpers disconnected. Their position is irrelevant when SWPD is disconnected.

HOW THE SWEEP CYCLE WORKS

An internal 12-minute timer is started when the drive becomes ready following Power-On or Slave Reset. The drive enters the sweep enable mode when the 12-minutes elapses. While in this mode, the first seek operation initiated by the controller causes a sweep segment. A seek operation is generated when the controller issues a Load Cylinder Address (04) or Load Position (05) Bus Control.

Following the sweep segment, the drive seeks to the cylinder specified in the Bus Control and returns the normal response. At that time, the 12-minute timer restarts and the cycle is repeated. A sweep segment adds 150 msec to the overall time for that specific seek operation. When the drive is in the sweep cycle mode and no seeks are generated by the controller, there will be no sweep segments.

If the drive is idle for long periods of time when using the sweep cycle feature, it is recommended that seek operations (any length other than zero-track) be initiated by the controller at regular intervals so that sweep segments are initiated.

CHECKING LOCAL MODE OPERATION

This procedure verifies that the drive power on sequence works properly in the Local mode.

1. Place the Remote/Local switch on the I/O board in the Local position.

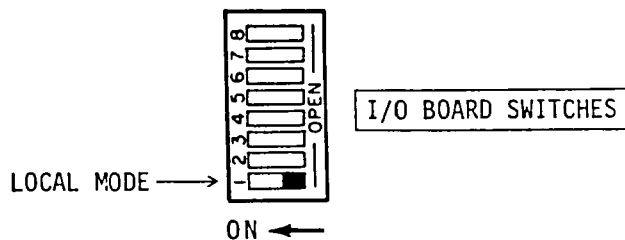

NOTE

If operator or status/control panel is not used, drive power on sequence starts when power supply On/Standby switch is placed in On position.

2. Set On/Standby switch on power supply to On (1) and observe that power supply cooling fan is operating.

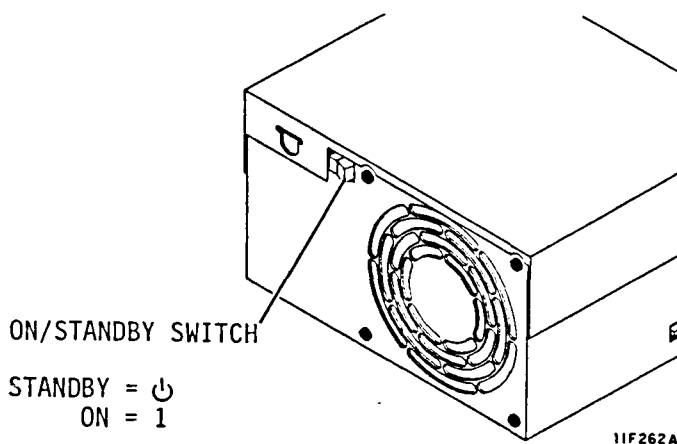

3. Press START switch if drive has an operator or status/control panel. Otherwise, skip this step.

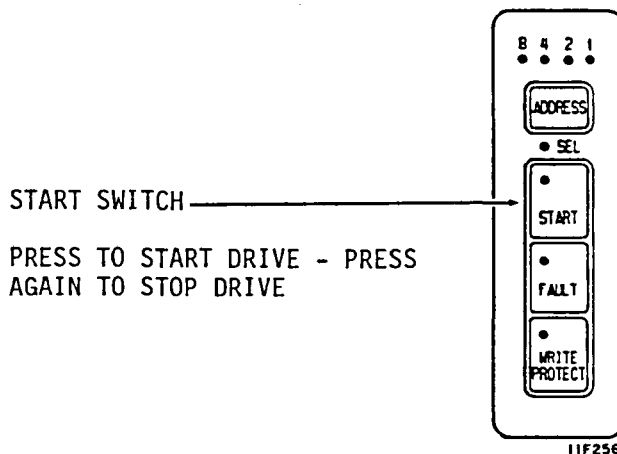

CHECKING LOCAL MODE OPERATION (CONTD)

4. Note Ready indicator in START switch flashes rapidly. This means power up sequence has started.
5. Ready indicator stops flashing but stays on within 90 seconds. This means the drive motor is up to speed and the heads are at track 0.

RDY LED on control board lights to indicate the drive is ready.

Refer to section 4 of this manual or to the maintenance manual if a problem exists in the drive.

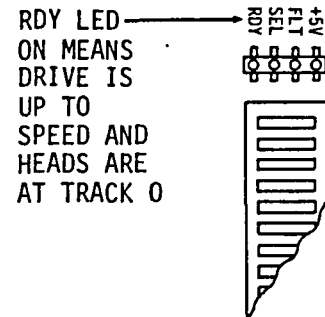
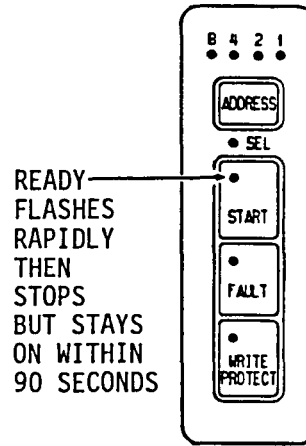

11F298A

CHECKING REMOTE MODE OPERATION

This procedure verifies that the drive power on sequence works properly in the Remote mode.

1. Place the Remote/Local switch on the I/O board in the Remote position.

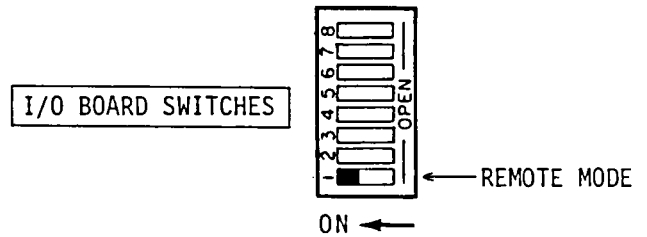

11F366A

2. Set On/Standby switch on power supply to On (1) and observe that power supply cooling fan is operating.

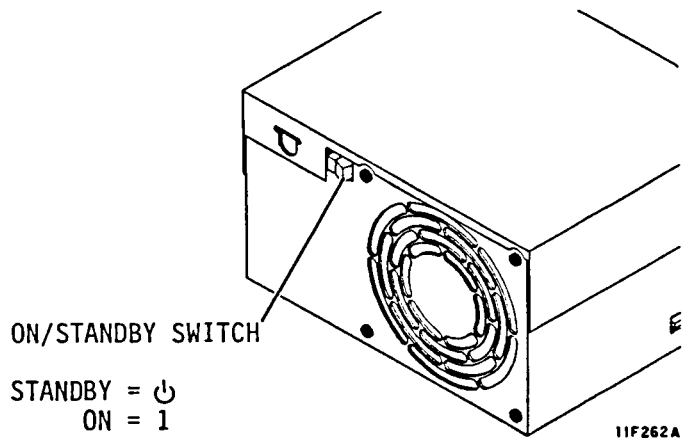

11F262A

3. Press START switch if drive has an operator or status/control panel. Otherwise, skip this step.

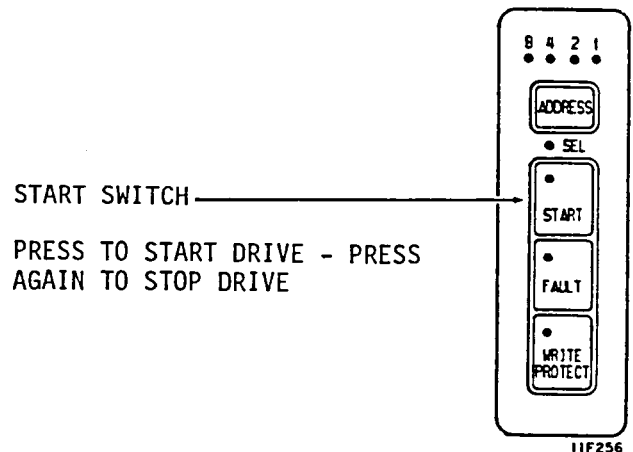

11F256

CHECKING REMOTE MODE OPERATION (CONTD)

- Issue Spin Up command to start the drive.

NOTE

Each drive power on sequence is delayed for a time equal to five seconds times its logical address. If logical address is 3, drive starts after 15 second delay.

Address 0	=	0	second delay
Address 1	=	5	second delay
Address 2	=	10	second delay
Address 3	=	15	second delay
Address 4	=	20	second delay
Address 5	=	25	second delay
Address 6	=	30	second delay
Address 7	=	35	second delay

- Note Ready indicator in START switch flashes rapidly. This means power up sequence has started.
- Note Ready indicator stops flashing but stays on within 90 seconds. This means drive motor is up to speed and heads are at track 0.

RDY LED on control board lights to indicate drive is ready.

Refer to section 4 of this manual or to the maintenance manual if a problem exists in the drive.

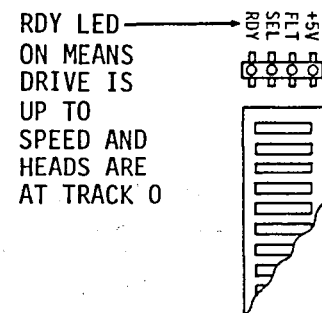
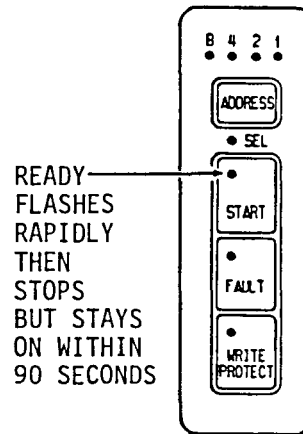

11F298A

ADDING AN OPERATOR PANEL OR STATUS/CONTROL PANEL

Use this procedure to add an optional operator panel or status/control panel to an existing 2X installation.

1. Remove the front panel insert from each drive.
2. Push the left 2X drawer latch to the right and fully extend 2X drawer. The release latch for the right drive is not used.

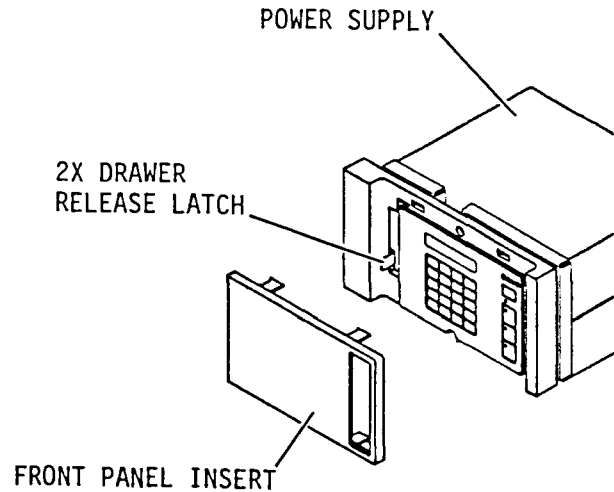

11F261

3. Set On/Standby switch on power supply to Standby position.
4. Remove screws securing front panel to inner drawer. Remove front panel and filter from drawer.
5. Disconnect the ac power cord from the power source.
6. Disconnect the I/O cables at the rear of the drive.

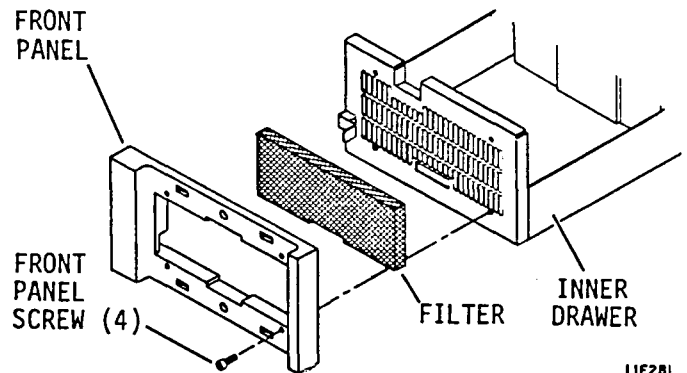

11F281

ADDING AN OPERATOR PANEL OR STATUS/CONTROL PANEL (CONTD)

7. Remove inner drawer locking screw. Push 2X drawer latch to right, lift inner drawer up and slide it forward and out of 2X drawer. Place inner drawer on a work table.

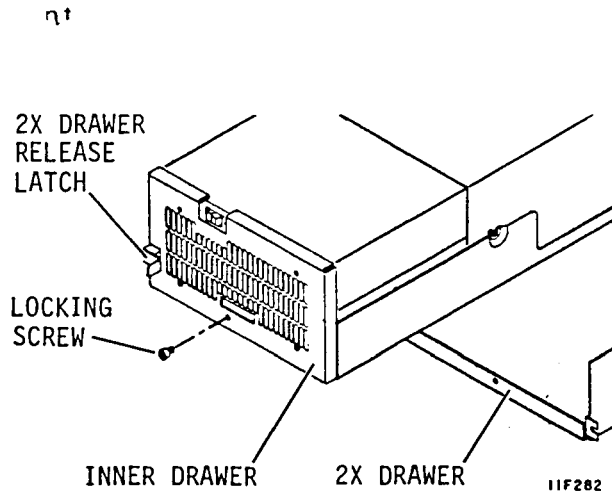

8. Remove air baffle (if used).
9. Loosen shock mount screws securing drive to inner drawer.
10. Disconnect power supply ground strap above shock mount on left side of drive.
11. Some drives also have a ground strap at each shock mount. Disconnect these where used.
12. Lift up front of drive and disconnect dc power cable from J15A on control board.
13. Lift drive from inner drawer and set on table.

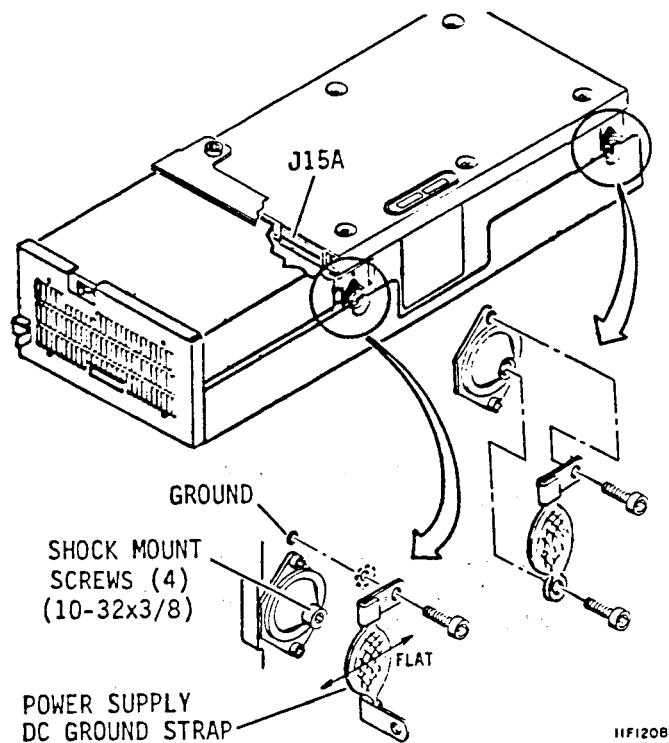

ADDING AN OPERATOR PANEL OR STATUS/CONTROL PANEL (CONTD)

14. Remove screws holding power supply to inner drawer.
15. Lift power supply from inner drawer and disconnect ac power cord from J1.

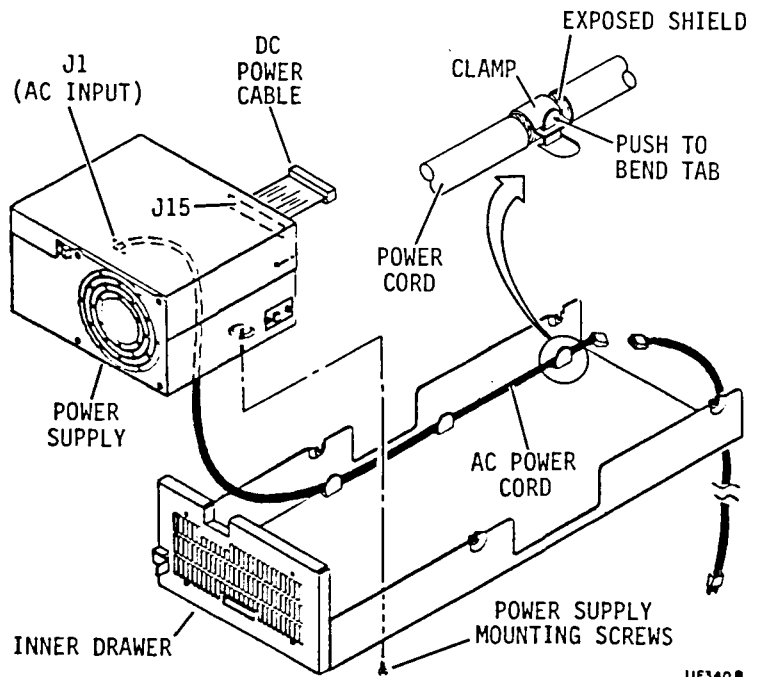

11F340 B

16. Perform the following procedures in the order listed. All procedures are in the listed sequence earlier in this section.
 - Installing the Operator Panel or Status/Control Panel Jumper Cable
 - Installing the Power Supply in the Inner Drawer
 - Installing the Drive in the Inner Drawer
 - Installing the Inner Drawer into the 2X Drawer
 - How to Mount the Status/Control Panel, or How to Mount the Operator Panel
17. Connect I/O and system ground cables.
18. Connect ac power cord to power source.
19. Place On/Standby switch on power supply to On (1).
20. Place 2X drawer in its closed position in rack.

SECTION 3. OPERATING THE DISC DRIVE

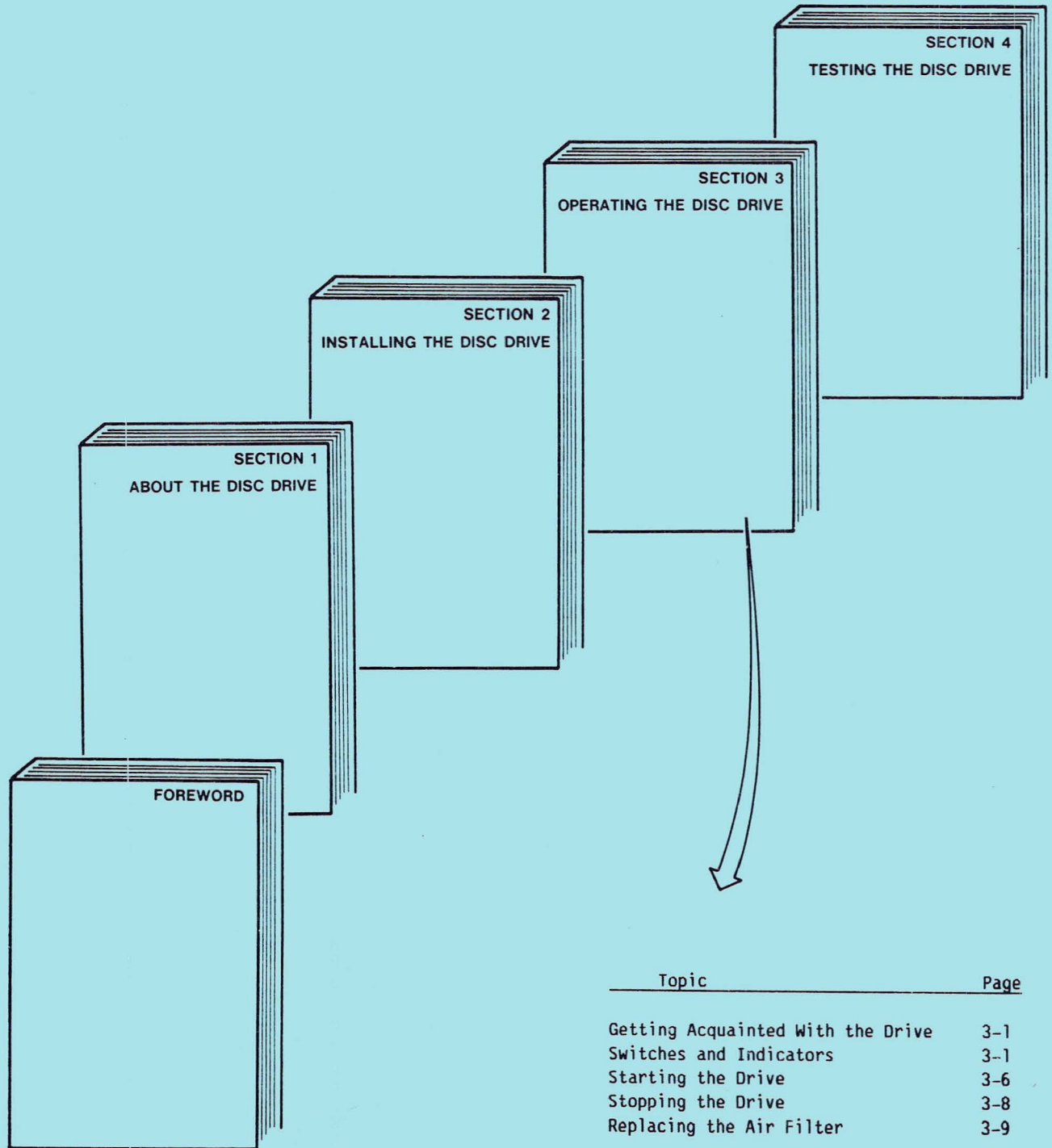

Topic	Page
Getting Acquainted With the Drive	3-1
Switches and Indicators	3-1
Starting the Drive	3-6
Stopping the Drive	3-8
Replacing the Air Filter	3-9

GETTING ACQUAINTED WITH THE DRIVE

This section explains the controls you use to operate the drive, how to start and stop the drive, how to interpret lighted indicators, and how to change the air filter.

The operator panel shown is optional. A blank panel is provided if the drive does not have an operator panel. If the drive does not have an operator panel, its operation depends on how the various switches were set when the drive was installed.

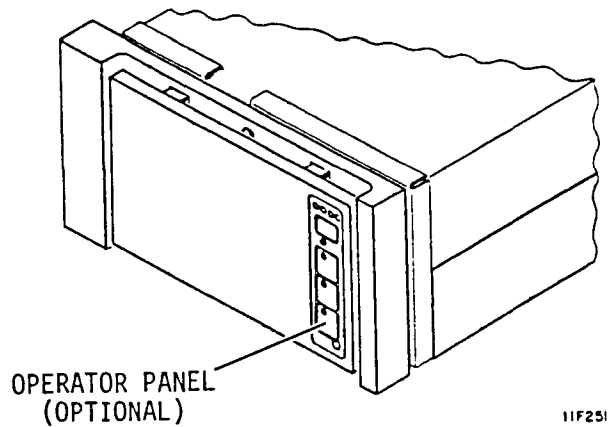

THE ADDRESS INDICATORS

The address indicators show the binary logical address of the drive. This address is determined and set when the drive is installed. It is stored in memory when dc power is off. Although the operator panel allows any address from 0 to 7, you must choose logical address from 0 to 7 (an IPI requirement). No two drives in the same string can have the same address. The address can be changed with the ADDRESS switch.

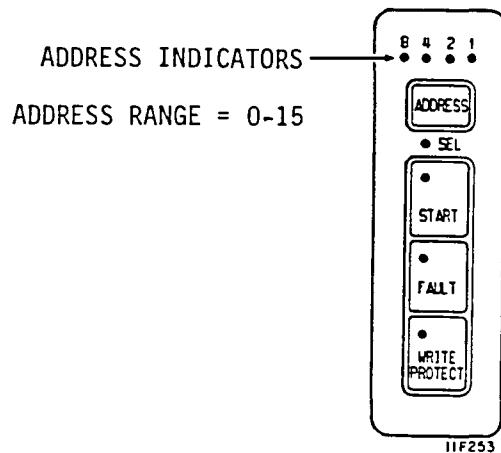

THE ADDRESS SWITCH

This switch is used to set the logical address of the drive. Pressing it for 2 to 3 seconds advances the logical address as displayed by the address indicators. Pressing and holding the switch longer than 3 seconds advances the logical address continuously.

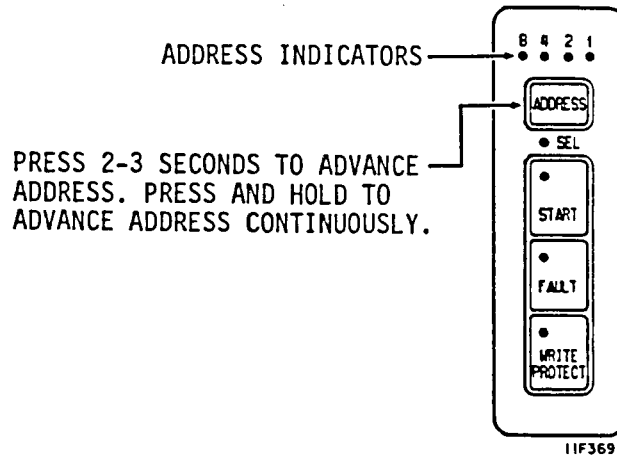

THE SEL (SELECTED) INDICATOR

When on, this indicator tells you the drive is selected by a controller. When off, it tells you the drive is not selected.

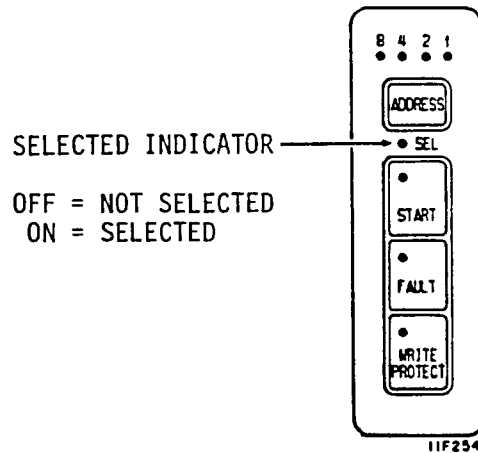

THE READY INDICATOR

The Ready indicator is in the upper left corner of the START switch.

This indicator flashes rapidly during the start cycle. It stops flashing but remains on when the start cycle ends to indicate the discs are up to speed and the heads are loaded and no fault conditions exist.

The indicator flashes slowly during the stop cycle. It stops flashing and remains off when the stop cycle ends.

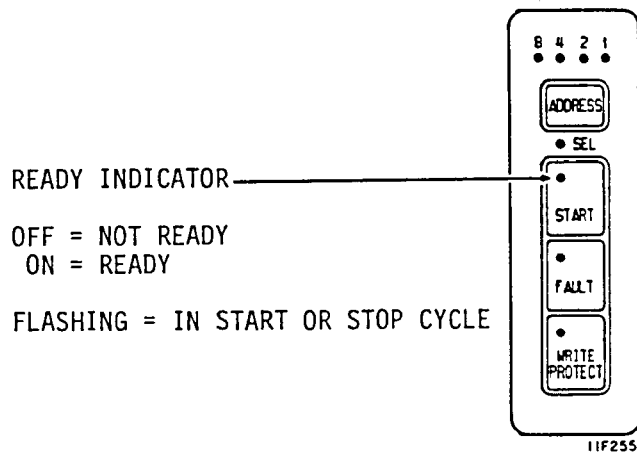

THE START SWITCH

Pressing and releasing this switch starts the drive. The Ready indicator in the upper left corner of the switch flashes rapidly during this cycle. It stops flashing but remains on when the start cycle ends.

Pressing and releasing the switch again causes the drive to begin its stop cycle. The Ready indicator flashes slowly during this cycle. It stops flashing and remains off when the stop cycle ends. The current condition of the START switch is stored in memory when dc power is removed.

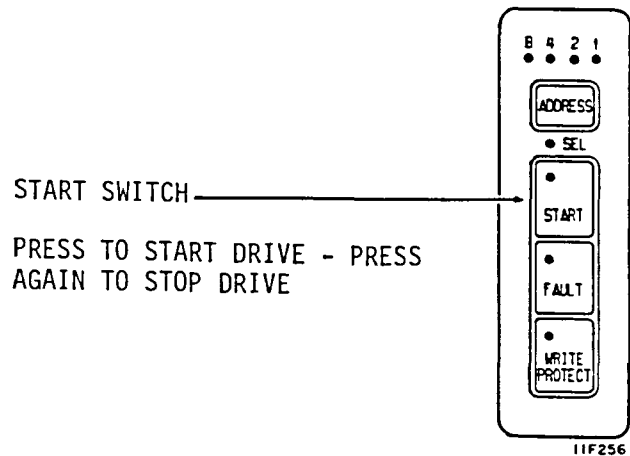

THE FAULT INDICATOR

This indicator is in the upper left corner of the Fault Clear switch. It lights if a fault condition exists within the drive. The indicator is turned off by any of the following, provided the fault condition is no longer present.

- Pressing the Fault Clear switch
- Reapplying dc power
- A Slave or Logical Selective Reset command from the controller

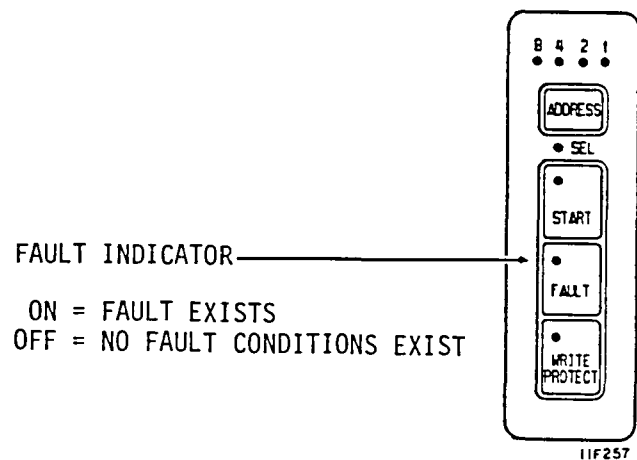

THE FAULT CLEAR SWITCH

Pressing and releasing this momentary action switch turns off the FAULT indicator, provided the fault condition that caused the indicator to light is no longer present.

FAULT CLEAR SWITCH
PRESS TO TURN OFF FAULT INDICATOR

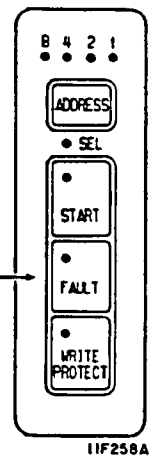

11F258A

THE WRITE PROTECT INDICATOR

The WRITE PROTECT indicator is in the upper left corner of the WRITE PROTECT switch. When this indicator is on, the write protect mode is selected and the drive is prevented from writing. The drive can read or write when this indicator is off.

WRITE PROTECT INDICATOR
ON = PREVENTS WRITING
OFF = PERMITS WRITING

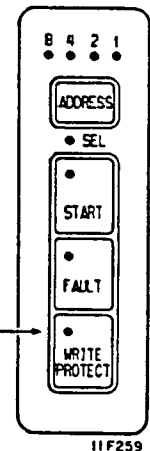

11F259

THE WRITE PROTECT SWITCH

Pressing this switch turns on the WRITE PROTECT indicator and prevents write operations. Pressing the switch again turns off the indicator and allows read or write operations. The current mode is stored in memory when dc power is removed. The WRITE PROTECT switch does not change the selection if the WP/N switch on the control board is set to WP (write protect).

WRITE PROTECT SWITCH
PRESS TO TURN ON INDICATOR AND PREVENT WRITE OPERATIONS
PRESS AGAIN TO TURN OFF INDICATOR AND ENABLE WRITE OPERATIONS

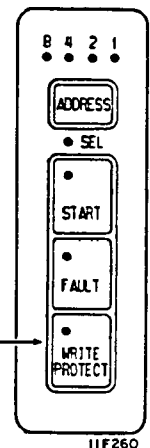

11F260

THE POWER SUPPLY ON/STANDBY SWITCH

The On/Standby switch is on the power supply. This switch controls dc power to the drive and is not routinely used. To reach the switch --

1. Remove the front panel insert.
2. Push the release latch to the right.
3. Extend the 2X drawer from the rack to expose the power supply.

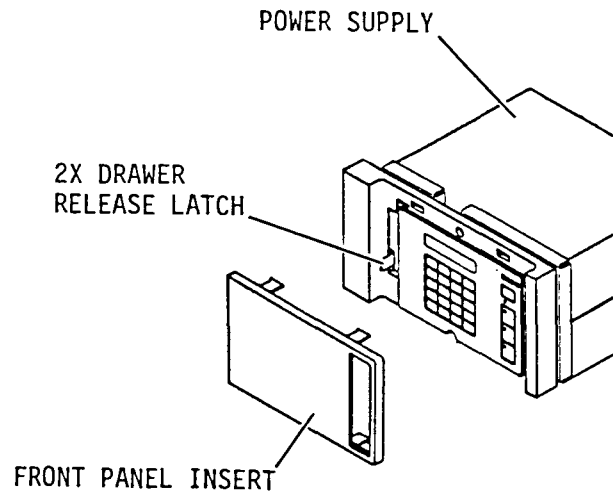

11F261

Placing the switch in the On position applies dc power to the drive and starts the cooling fan.

Placing the switch in the Standby position removes dc power from the drive and stops the fan.

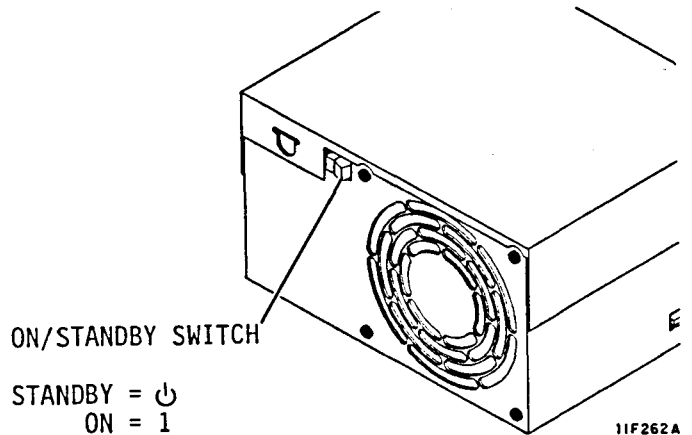

11F262A

HOW TO START A DRIVE WITH NO OPERATOR PANEL

Drives with no operator panel are not routinely turned on and off. Power is normally left on and the drive motor is started and stopped using the Spin Up and Spin Down function codes. Use the following procedure to start the drive:

1. Set the On/Standby switch on the power supply to On (1).

NOTE

In Local mode, the drive starts immediately when the On/Standby switch is set to On (1). In Remote mode, starting of each drive can be delayed from 0 to 35 seconds depending on its logical address. The delay period is 5 seconds times the logical address. A drive with a logical address of 5, starts after a 25 second delay expires.

2. Repeat step 1 for all drives in the string. After 90 seconds all drives should be started and ready to respond to controller commands.

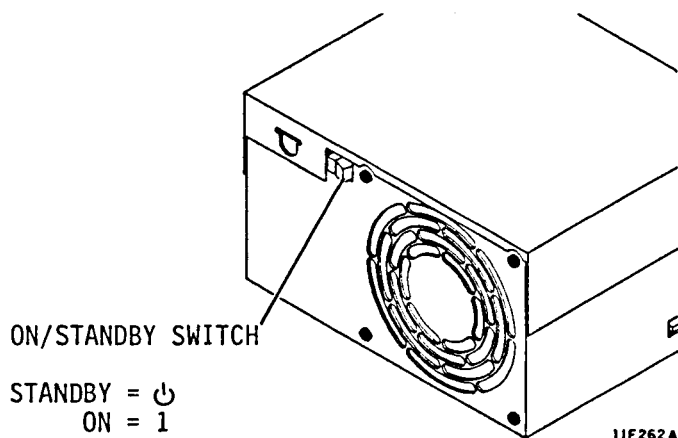

HOW TO START A DRIVE WITH THE OPTIONAL OPERATOR PANEL

1. Set the power supply On/Standby switch to On (1).

NOTE

In Local mode, the drive starts immediately when the START switch is pressed. In Remote mode, start up of each drive can be delayed from 0 to 35 seconds depending on its logical address. The delay period is 5 seconds times the logical address. A drive with a logical address of 5, starts after a 25 second delay expires.

2. Press the START switch.
3. After the delay period (if applicable) observe that the Ready indicator flashes rapidly.

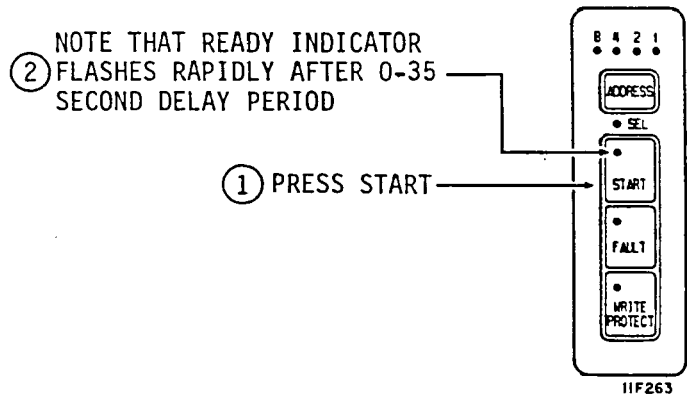

4. Observe that the Ready indicator stops flashing within 90 seconds, but remains on.
5. Observe that the FAULT indicator is off. The drive is now ready to respond to commands from the controller.

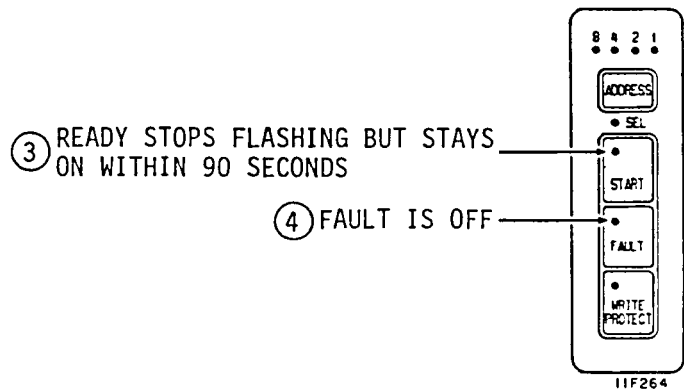

HOW TO STOP THE DRIVE

A drive can be stopped in any one of three ways:

- Using the operator panel
- Using the power supply On/Standby switch
- Using the Spin Down function.

STOPPING THE DRIVE USING THE OPTIONAL OPERATOR PANEL

1. Press the START switch.
2. Observe that the Ready indicator flashes slowly.
3. Observe that the Ready indicator stops flashing and remains off within 60 seconds.

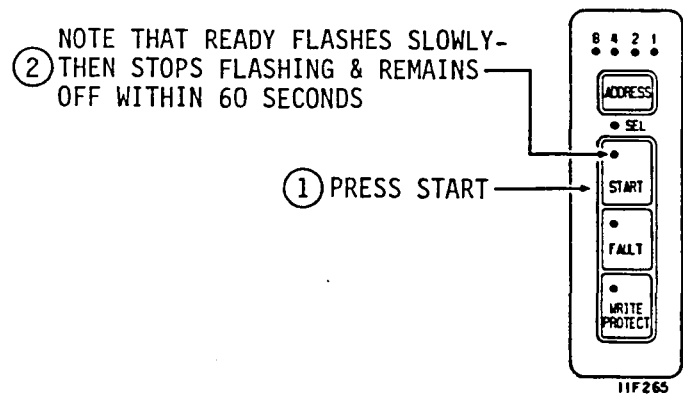

STOPPING THE DRIVE USING THE POWER SUPPLY ON/STANDBY SWITCH

1. Set the On/Standby switch on the power supply to the Standby position.
2. The power supply fan stops and the drive stops within 60 seconds.

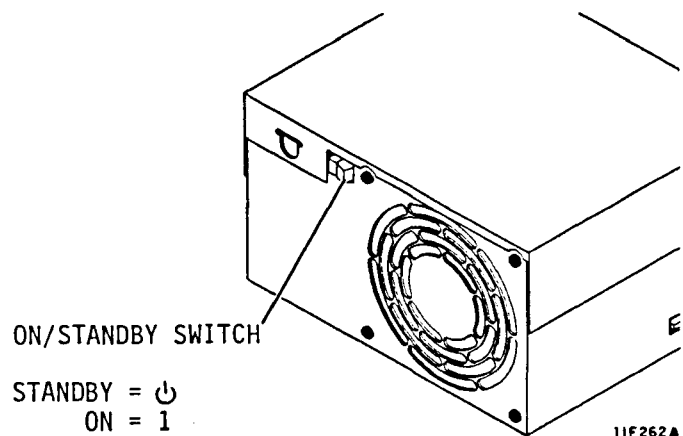

USING THE SPIN UP/SPIN DOWN FUNCTION

When the Local/Remote switch on the I/O board is in the Remote position, the Spin Down function can be used to stop the drive after it has once been started. The Spin Up function can be used to start the drive only after dc power is applied. The sequence of events when the drive receives this command is the same as pressing the START switch on the optional operator panel.

DUAL PORT FAILURES

Failure of one controller in a dual port configuration can cause problems in all drives attached to it. If a failure of this type does occur, the affected port on each drive should be disabled. Contact the person responsible for maintenance of the system.

HOW TO REPLACE THE AIR FILTER

The air filter is located behind the front panel insert. It must be checked frequently and replaced when it is dirty. Clean the air filter only if a replacement is not available.

1. Remove the front panel insert from the drive.
2. Push the release latch to the right and extend the 2X drawer to gain access to the power supply.
3. Stop the drive. Place the On/Standby switch on the power supply in the Standby position.

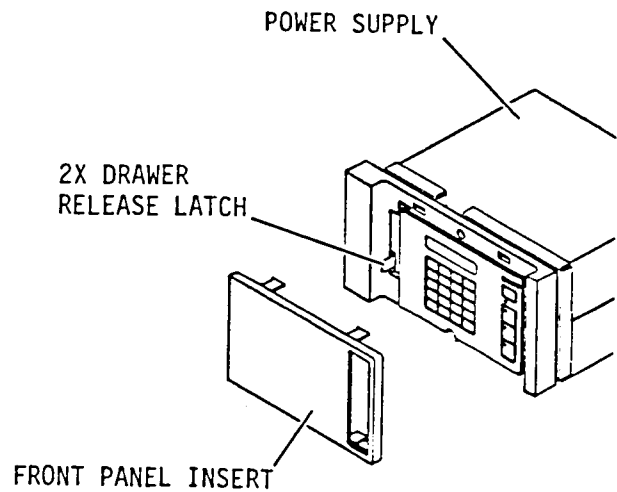

11F261

HOW TO REPLACE THE AIR FILTER (CONTD)

NOTE

Skip steps 4 and 7 if the drive does not have the optional status/control panel.

4. Remove the two screws that secure the status/control panel to the front panel. Move it away from the front panel to gain access to the air filter.
5. Remove the dirty filter. If a clean, replacement filter is not available, clean the dirty filter in a solution of water and mild detergent. Rinse the filter and allow it to dry thoroughly.
6. Install the clean filter.
7. Place the status/control panel on the front panel and secure it with the two screws.
8. Set the On/Standby switch on the power supply to the On (1) position.
9. Push the 2X drawer fully into the rack until it latches.
10. Install the front panel insert.

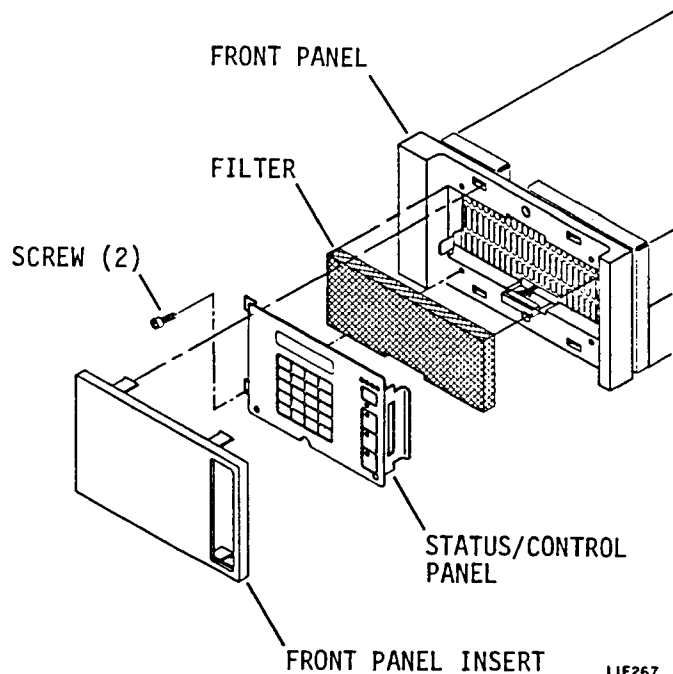

SECTION 4. TESTING THE DISC DRIVE

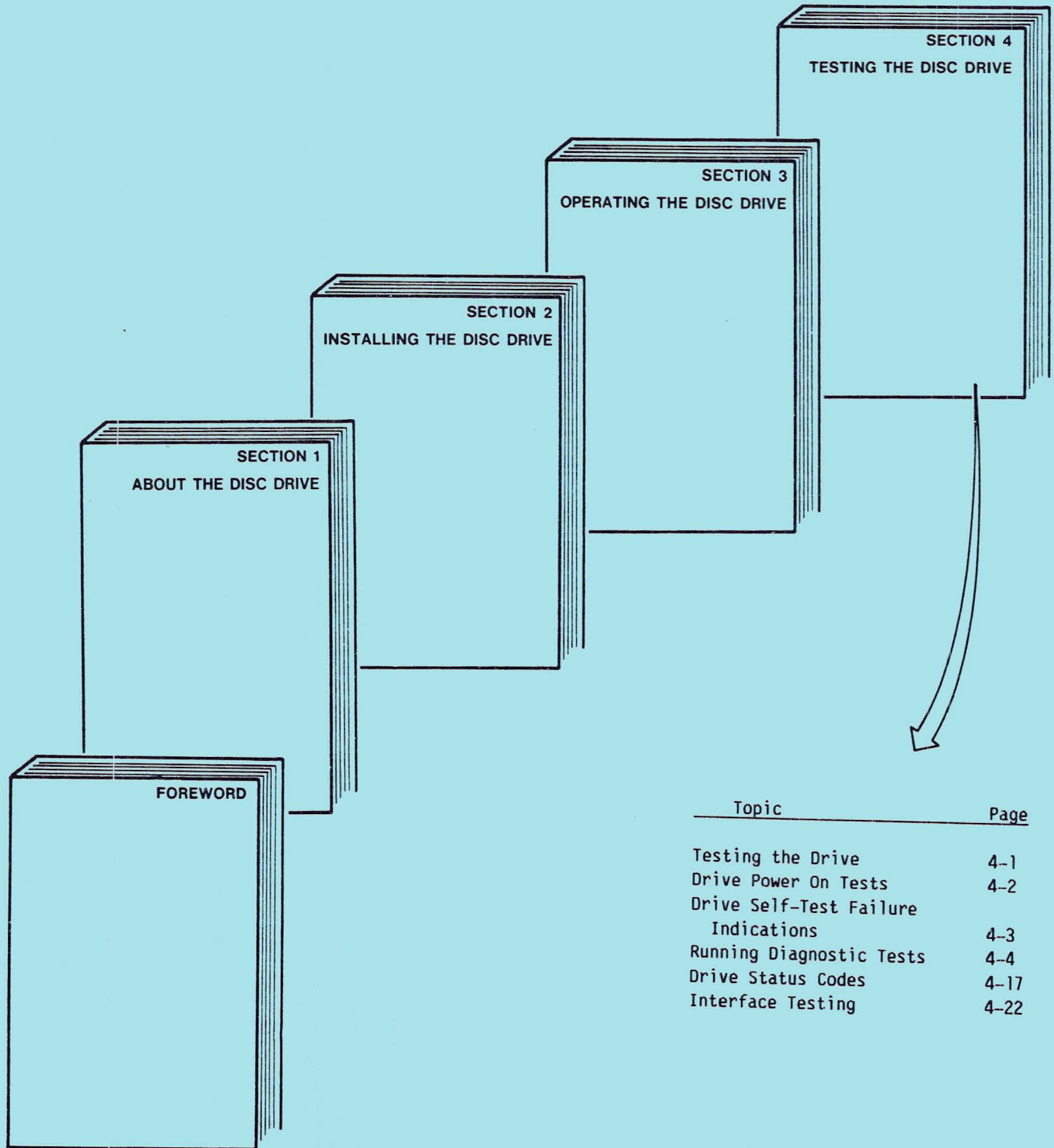

Topic	Page
Testing the Drive	4-1
Drive Power On Tests	4-2
Drive Self-Test Failure Indications	4-3
Running Diagnostic Tests	4-4
Drive Status Codes	4-17
Interface Testing	4-22

ABOUT TESTING THE DRIVE

CAUTION

When servicing the drive, observe all of the precautions listed under Electrostatic Discharge Protection in section 2 of this manual. Failure to observe these precautions can result in serious damage to electronic assemblies.

This section briefly explains the various diagnostic tests, how to run them, and how to interpret the information displayed on the optional status/control panel. Refer to the maintenance manual for detailed troubleshooting information.

A status/control panel is needed for trouble analysis. If the drive installation does not include a status/control panel, you should connect one to the drive for troubleshooting. Part numbers for the status/control panel and its interconnecting cable can be found in the parts data manual. Instructions for installing the status/control panel are provided in section 2 of this manual. When using the status/control panel for trouble analysis, disable the I/O using the port disable switches (DA - DB) on the I/O board as described in section 2. Failure to disable the I/O may prevent status/control panel initiated diagnostics from completing and the LCD may go blank due to controller selection of the drive.

The following types of troubleshooting information are provided in this section:

- Drive Power On Tests -- describes the self-tests that occur when dc power is applied to the drive, and lists the corrective actions to take if a test failure occurs.
- Diagnostic Testing -- describes how to use offline diagnostic testing to isolate drive malfunctions.
- Drive Status Codes -- provides information on correcting problems associated with drive power-up/down and with servo operations.
- Interface Testing -- describes the I/O MPU self-tests and online diagnostics.

DRIVE POWER ON TESTS

The Control MPU starts a series of tests on the drive circuits when dc power is applied. The Ready, FAULT, and WRITE PROTECT lights on the operator or status/control panel are on during these tests. The Address indicators display the test number being run.

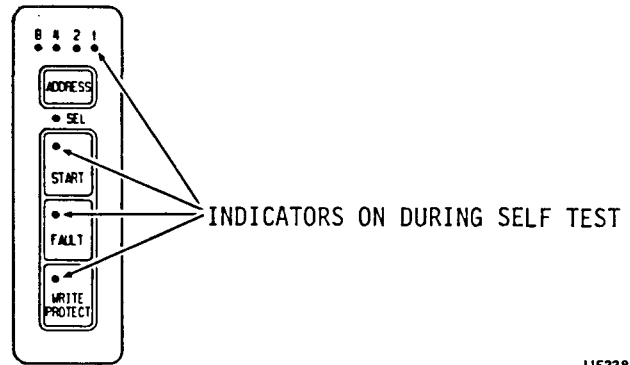

11F228

The FAULT light turns off in about four seconds. This means the self-test ran error-free.

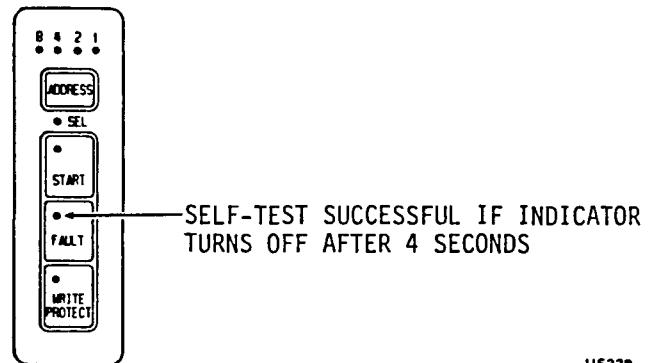

11F229

The drive failed the self-test if the Ready and FAULT lights stay on constantly. The Address indicators show which self-test routine the drive failed to complete. Refer to the Drive Self-Test Failure table on the next page to determine which test failed and what action to take. If the Control MPU is unable to communicate with the optional status/control panel, PANEL FAILURE is displayed on the status/control panel LCD.

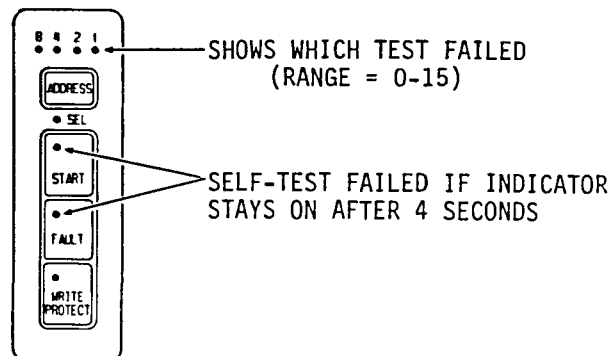

11F230

DRIVE SELF-TEST FAILURE INDICATIONS

Address Lights*	Hex Code	Test Failed** & Actions
8 4 2 1		
• • • •	F	<u>RAM Test</u> Action: Replace control board.
• • • 0	E	<u>ROM Test</u> Action: Replace control board.
• • 0 •	D	<u>I/O Chip Test</u> Actions: 1. Replace I/O board. 2. Replace control board.
• • 0 0	C	<u>Peripheral Chip (Test 1)</u> Action: Replace control board.
• 0 • •	B	<u>Peripheral Chip (Test 2)</u> Action: Replace control board.
• 0 • 0	A	<u>Motor MPU Test</u> Action: Replace control board.
<p>* Darkened circles means light is On.</p> <p>** Ready and FAULT lights stay on, indicating drive failed four second power-on self-test.</p>		

ABOUT THE OFFLINE DIAGNOSTIC TESTS

The available offline tests are shown at the right. How you select and run the tests is described on the following pages.

Do not attempt to enter a test number that is not listed. Doing so causes invalid test results. The drive does not run tests that require seeks (05, 08, 09, or OE) unless the spindle motor is up to speed and the heads are loaded. The LCD displays SPEED NOT OK if the spindle is not up to speed when the test is selected. The LCD displays ACT PARKED if the actuator was parked and locked when the test was selected.

If you temporarily connect a status/control panel to the drive for troubleshooting, run tests 06 and 07 before you continue with other tests. When drive power is removed, the panel stores its status log and fault log in a nonvolatile RAM. When power is initially applied to the drive, these logs may reflect operation of the panel as it was used on a different drive.

Test	Description
00	Display drive operating status log.
01	Display fault log
04	Calculate three most likely field replaceable units
05	Servo test
06	Clear drive operating status log
07	Clear fault log
08	Direct or continuous seek
09	Random seek
OC	Display EPROM part number
OE	Return to zero

HOW TO SELECT AND RUN DIAGNOSTIC TESTS

Use the procedure below to select and run the diagnostic tests. Run tests 06 and 07 before any other test if you connected a status/control panel only temporarily. Its internal status and fault logs may reflect operation with another drive. Entering test numbers other than those described in this section will produce invalid test results. SPEED NOT OK or ACT PARKED is displayed on the LCD if the drive is not up to speed or the heads are not loaded when running a test that does seeks (05, 08, 09, and 0E).

1. Disable the I/O using the port disable switches as described in section 2. Failure to disable the I/O may prevent diagnostics from completing and the LCD may go blank if the controller selects the drive.
2. Press DIAG MODE switch to enter diagnostic mode.
3. Observe that LCD reads DIAG TEST XX.
4. Enter a two hexadecimal character test number on keyboard and press EXEC switch to select first test.

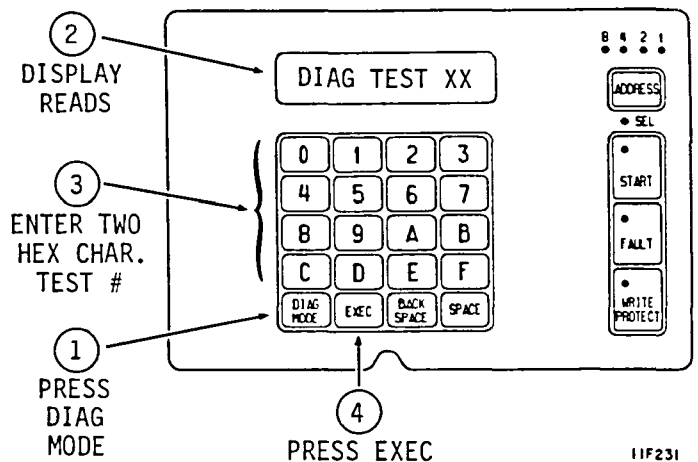

11F231

Pressing the EXEC switch one more time ends the test. The LCD again reads DIAG TEST XX.

You now have two choices:

- Enter two hexadecimal characters on keyboard and press EXEC switch to select another test, or
- Press DIAG MODE switch to leave diagnostic mode. The LCD displays drive operating status. Reenable the I/O using the port disable switches (see section 2).

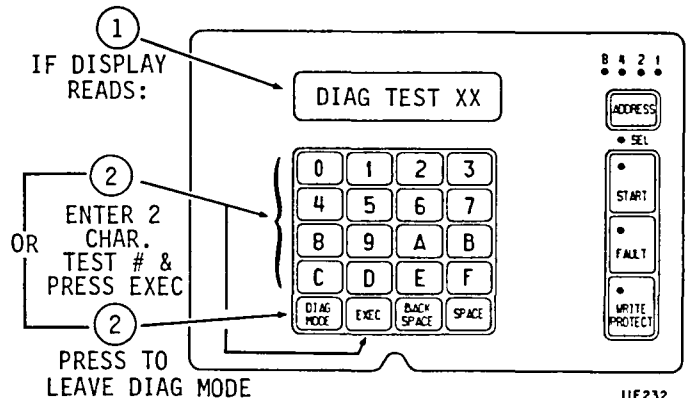

11F232

TEST 00 -- DISPLAY DRIVE OPERATING STATUS LOG

This test displays the eight most recently generated drive status codes. After test selection, the display provides a hexadecimal status code from the internal log. This code is preceded by a character (0-7) and a colon, indicating the position of the status code in the status log. To execute test 00, perform the following steps:

1. Enter Test 00 and press EXEC switch. The LCD reads DRIVE LOG: 0:XX where 0 is the position in log and XX is status code in that position.

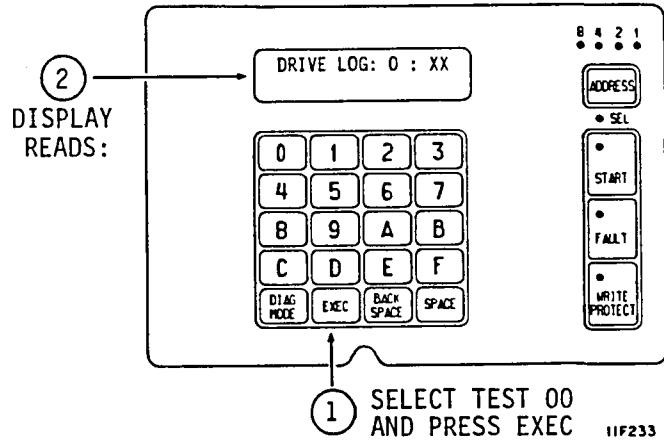

2. Press SPACE switch until a code appears, preceded by an asterisk. This is most recent code stored in status log.
3. Use SPACE switch to step through 8th most recent to most recent status.
4. Press EXEC switch to end test and return to test selection.

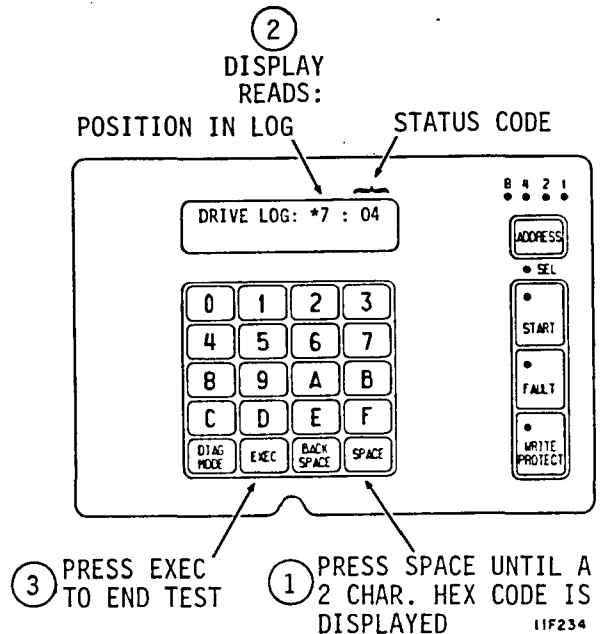

TEST 01 -- DISPLAY FAULT LOG

This test displays the eight most recently stored fault codes. After test selection, a hexadecimal fault code will be displayed. This code is preceded by a character (0-7) and a colon, indicating the position of the fault code in the fault log. Perform the following steps to execute test 01:

1. Enter Test 01 and press EXEC switch. LCD reads FAULT LOG: 0:XX where 0 is position in log and XX is fault code in that position.

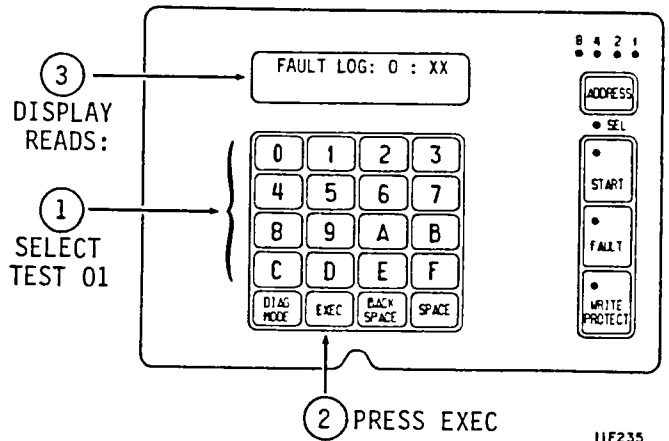

2. Press SPACE switch until a code appears, preceded by an asterisk. This indicates most recent code stored in fault log.
3. Use SPACE switch to step through from 8th most recent to most recent fault.
4. If more than one fault occurs simultaneously (multiple faults), more than one bit in fault code is set. Check bit-mapped locations of each fault in list on next page.

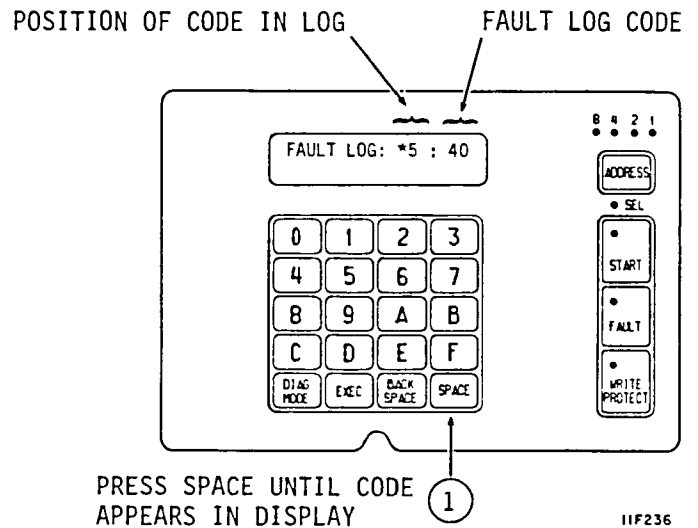

TEST 01 -- DISPLAY FAULT LOG (CONTD)

The first code shown in parenthesis in the following table is the code displayed on the status/control panel. The second code is the code reported to the interface.

<u>Bit</u>		<u>Definition</u>
0	(LSB)	Read•Write Fault (01/81)
1		(Read+Write)•Off Cylinder Fault (02/82)
2		First Seek Fault (04/84)
3		Write Fault (08/88)
4		Write•Write Protected Fault (10/90)
5		Head Select Fault (20/A0)
6		Voltage Fault (40/C0)
7	(MSB)	Not Used

5. Press EXEC switch to end test and return to test selection.

TEST 04 -- CALCULATE THREE MOST LIKELY FIELD REPLACEABLE UNITS

NOTE

Do not execute Tests 05, 06, or 07 prior to running Test 04.

This test uses the fault status and the drive operating status history (Tests 00 and 01) to predict the most likely cause of drive failure. To execute Test 04, perform the following steps:

1. Enter Test 04 and press EXEC switch. LCD reads FRUS: XX XX XX.

Three FRUs are displayed at end of test. First code is most probable cause of failure.

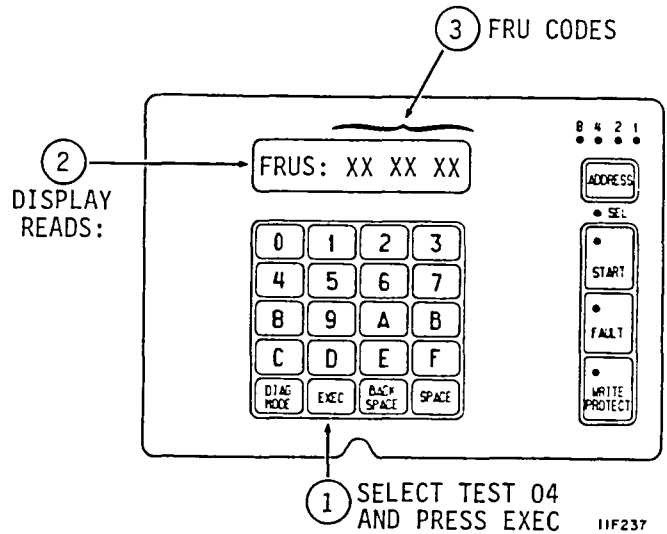

The FRU codes reported to the controller and displayed on the status/control panel are:

<u>Controller</u>	<u>Displayed</u>	<u>FRU</u>
80	00	No FRU Information
81	01	Replace Control Board
82	02	Replace Module
83	03	Replace Power Supply
84	04	Replace I/O Board
85	05	Replace Control Board
86	06	Replace Module

2. Press EXEC switch to end test and return to test selection.

TEST 05 -- SERVO TEST

This test clears the drive status log and fault log. Test 04 relies on status history that would be cleared by Test 05 so you may want to run Test 04 before running Test 05. Test 05 performs the seek operations listed below:

- RTZ (one time)
- One track seek (16 times)
- RTZ (one time)
- Partial servo recalibrate (one time)
- RTZ (one time)
- Maximum length seek (16 times)
- RTZ (one time)

The test stops if an error is detected or at the end of the test. Perform the following steps to run test 05:

1. Enter Test 05, then press the EXEC switch.

If test is successful
LCD reads OK, CYL: 000.

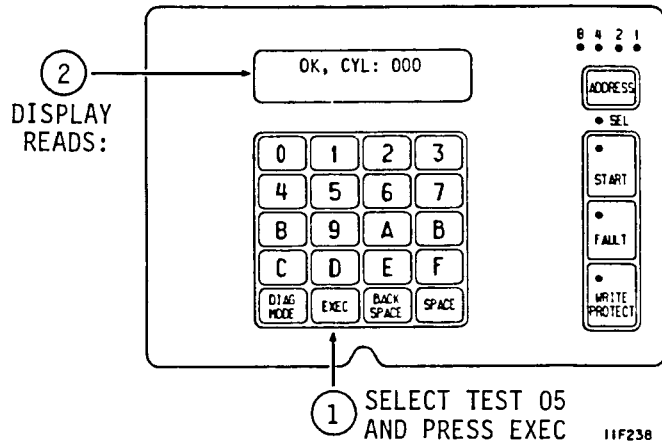

If error occurs, LCD displays SERVO ERROR:XX. Drive status codes (SERVO ERROR) are defined in table at end of this section.

2. Press EXEC switch to end test and return to test selection.

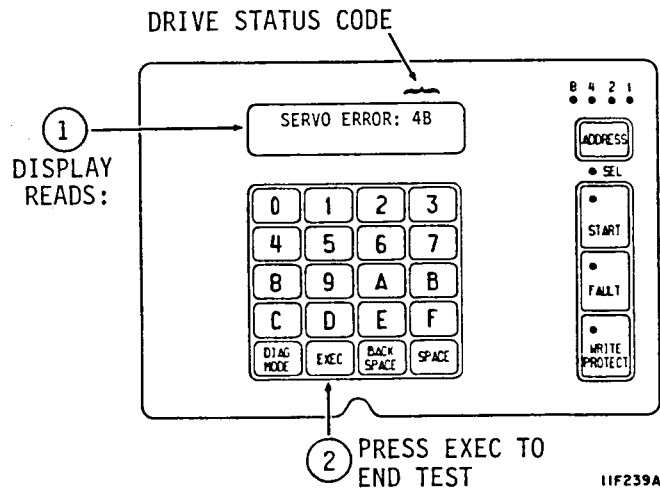

TEST 06 -- CLEAR DRIVE OPERATING STATUS LOG

This test clears the drive status log in the program RAM. Since Test 04 relies on status history that is cleared by Test 06 so you might want to run Test 04 before running Test 06. Perform the following steps to run Test 06:

1. Enter Test 06 and press EXEC switch.

LCD displays
DRIVE LOG CLEAR

2. Press EXEC switch to end test and return to test selection.

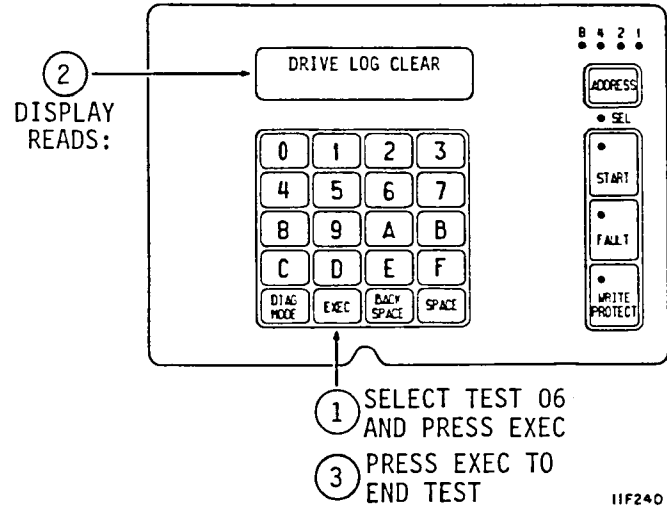

11F240

TEST 07 -- CLEAR FAULT LOG

This test clears the fault log. Test 04 relies on status history that is cleared by Test 07 so you might want to run Test 04 before running Test 07. Perform the following steps to run Test 07:

1. Enter Test 07 and press EXEC switch.

LCD reads
FAULT LOG CLEAR

2. Press EXEC switch to end test and return to test selection.

2
DISPLAY
READS:

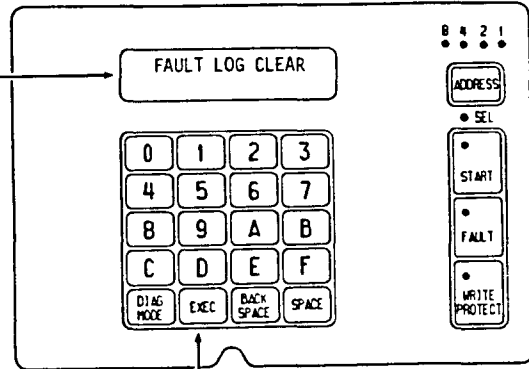

1
SELECT TEST 07
AND PRESS EXEC

3
PRESS EXEC TO
END TEST

11F241

TEST 08 -- DIRECT OR CONTINUOUS SEEKS

This test performs direct or continuous seeks between cylinder 0 and the desired cylinder address. The test ends if an error occurs or if the EXEC switch is pressed. Perform the following steps to run Test 08:

1. Enter Test 08 and press EXEC switch.
2. HEX CYL XXX tells you to enter valid hex cylinder address (between 0 and 564 for 850 MB drives or 0 and 663 for 1153 and 1230 MB drives). Enter three characters and press SPACE switch.

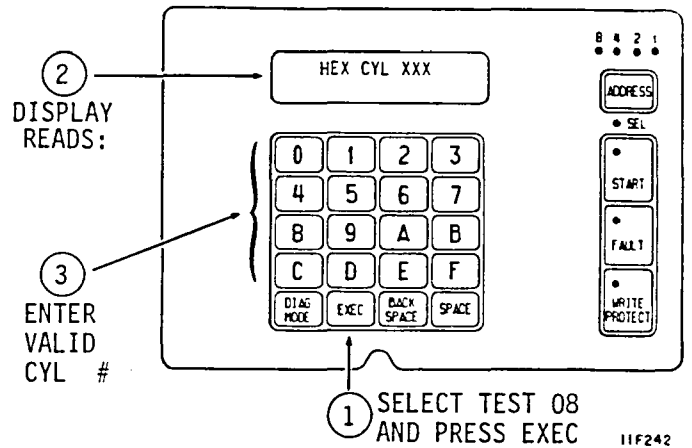

3. DIR OR CONT? D/C asks you to select either direct (D) or continuous (C) seeks. Enter either C or D to start test.

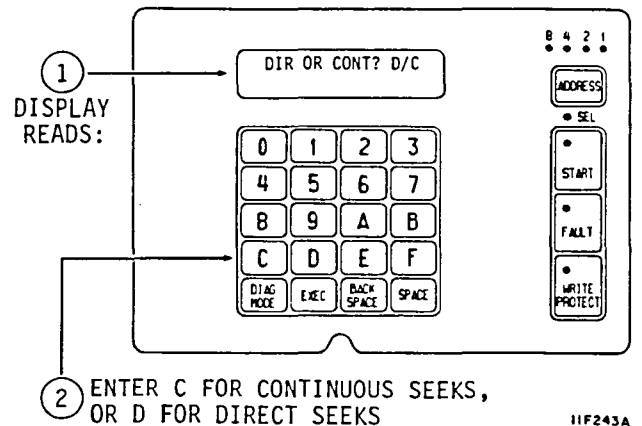

TEST 08 -- DIRECT OR CONTINUOUS SEEKS (CONTD)

4. If D was entered and direct seek is successful LCD displays OK, CYL: XXX where XXX is address previously entered.
5. Press the EXEC switch to end test and return to test selection.

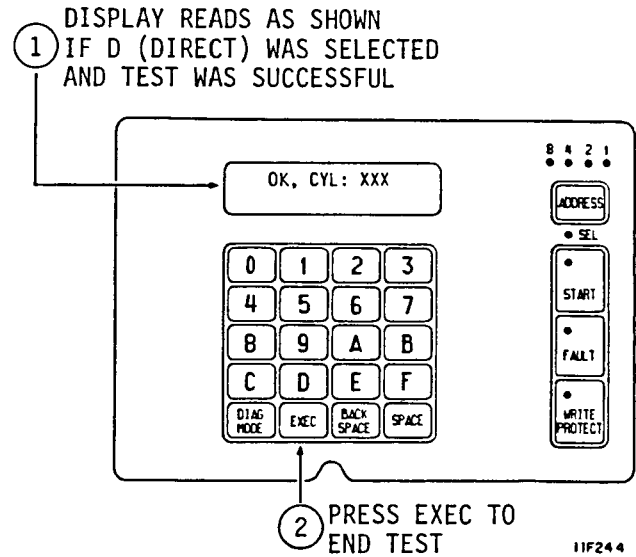

6. If either D or C was entered and an error occurs, LCD displays SERVO ERROR: XX.

Drive status codes (SERVO ERROR) are defined in a table at the end of this section. Clear seek errors by running Test 05 or Test 0E.

If C was entered, press EXEC switch to end test and return to test selection.

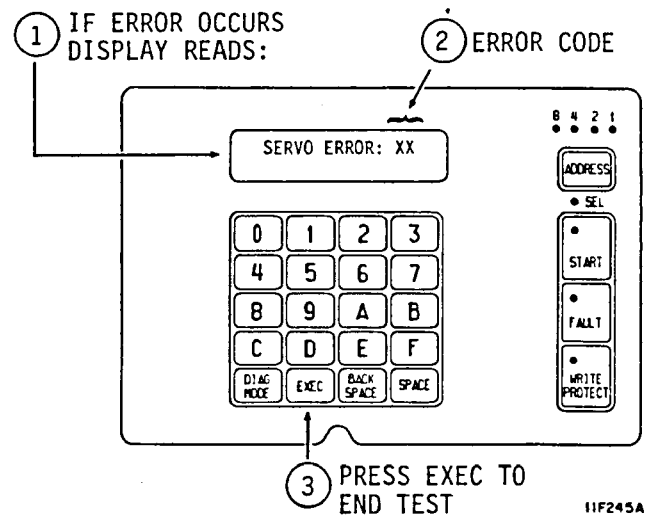

TEST 09 -- RANDOM SEEK

This test performs random seeks between cylinders 0 and the maximum cylinder address (1380 for 850 MB drives or 1634 for 1153 MB and 1230 MB drives). The test ends if an error is detected or by pressing the EXEC switch. Perform the following tests to run Test 09:

1. Enter Test 09 and press EXEC switch.
2. LCD reads OK, CYL: XXX if test is successful.
3. If an error occurs, LCD reads SERVO ERROR: XX. Drive status codes (SERVO ERROR) are defined in a table at end of this section.
4. Press EXEC switch to end test and return to test selection.

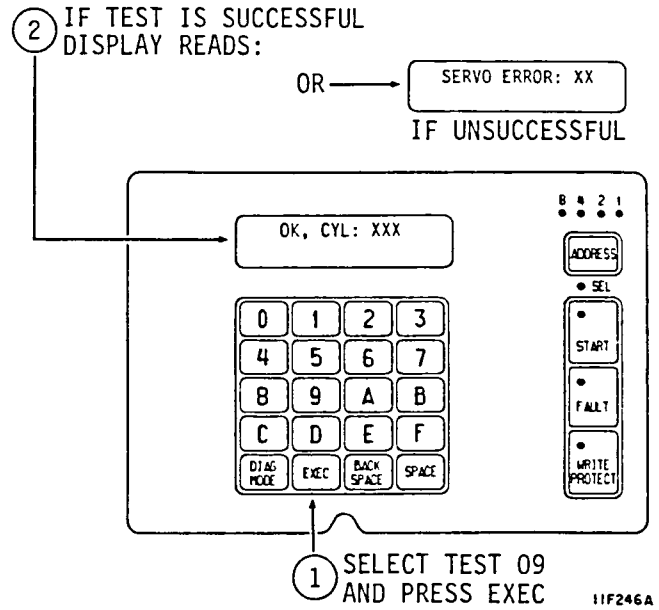

TEST OC -- DISPLAY EPROM PART NUMBER

This test displays the eight-digit part number of the control microprocessor EPROM. Perform the following steps to run Test OC:

1. Enter Test OC and press EXEC switch.

LCD displays eight-digit EPROM part number (for example EPROM# = 12345678).

2. Press EXEC switch to end test and return to test selection.

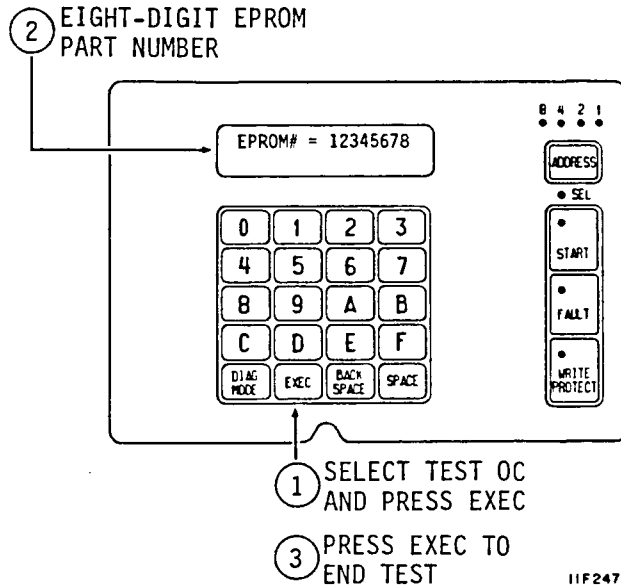

TEST OE -- RETURN TO ZERO

This test starts a return to zero command. Perform the following steps to run Test OE:

1. Enter Test OE and press EXEC switch.

LCD reads OK, CYL: 000.

2. If error occurs during test, LCD displays SERVO ERROR: XX. Drive status codes (SERVO ERROR) are defined in table at end of this section.

3. Press EXEC switch to end test and return to test selection.

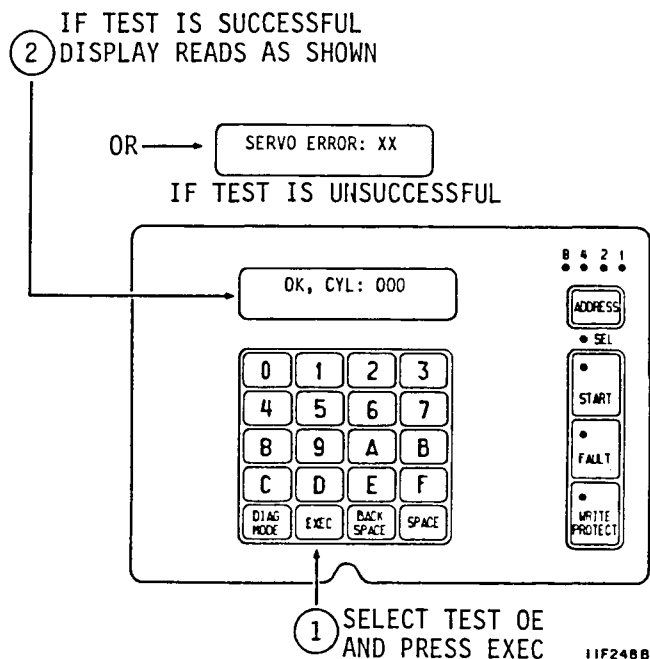

DRIVE STATUS CODES

The Control MPU periodically checks operation of the drive and generates appropriate operating status codes when the drive has dc power applied.

The table on the next page lists the status codes and provides a definition of each. If a drive malfunction occurs, observe the error code and perform Diagnostic Test 04 to calculate the action to be taken.

Shown at the right is an example of the LCD (Liquid Crystal Display) during normal operation. It displays the current drive status and cylinder address.

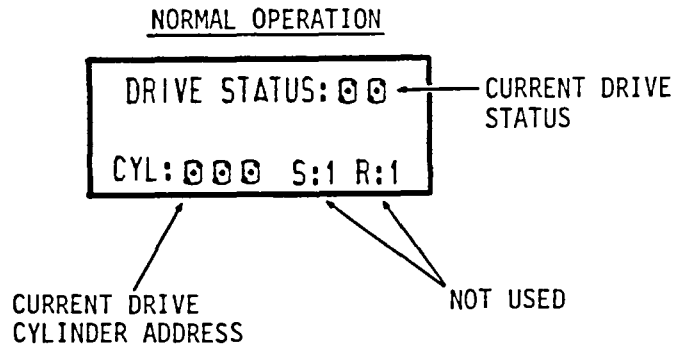

11F174A

If a fault occurs, the LCD displays the type of fault(s) that occurred along with the current drive status. If more than one fault occurred, use the SPACE switch to step through the fault log to determine what faults are present.

Pressing the Fault Clear switch clears the LCD fault display and the FAULT indicator provided the fault is no longer exists. A Fault Clear signal from the controller clears only the Fault indicator.

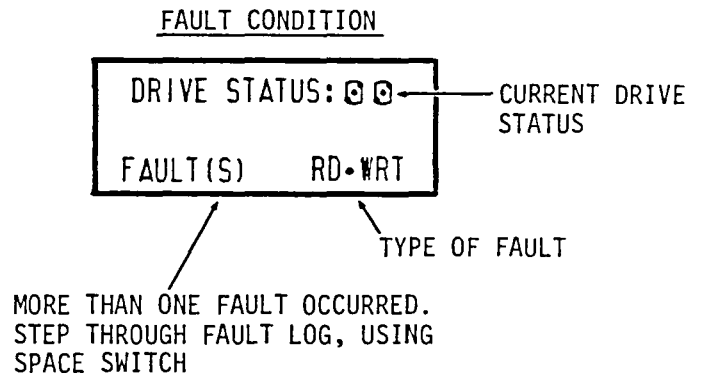

11F250

DRIVE STATUS CODES (CONTD)

Two status codes are shown for each entry in the following table. The first is the code reported to the interface and the second is the code displayed on the status/control panel.

Code	Title	Description
NORMAL START/STOP STATUS		
80/00	Ready & On Cylinder	Indicates the drive is on cylinder and ready for normal operation.
82/02	Motor Stopping	Indicates the motor is slowing or that motor braking is in progress.
83/03	Motor Stopped	Indicates the motor is stopped.
84/04	First Load/Calibrate	Indicates the heads are moving from the landing zone to track 0 and servo calibration is being performed.
85/05	Sequence Delay	This code appears in remote mode during power on sequence delay. Delay is determined by logical address assigned to drive. (delay = address X 5 seconds). Status changes to 87/07 after delay.
86/06	START pressed and waiting for power sequence signals	In remote mode, indicates START switch was pressed and drive is waiting for power sequencing control signals from interface. Code precedes delay.
87/07	Starting Motor	Indicates that start conditions (codes 85/05 and 86/06) were satisfied. Code remains 87/07 until motor reaches full speed.
88/08	Motor Up To Speed	Indicates the spindle motor has reached full speed.

Continued

DRIVE STATUS CODES (CONTD)

Code	Title	Description
I/O BOARD NORMAL STATUS		
89/09	I/O Self-Test Passed	I/O MPU successfully ran its power on self-test.
SWEEP CYCLE STATUS		
8A/0A	Drive in Sweep Cycle	Drive is seeking as part of sweep cycle. On cylinder is inactive at this time.
8B/0B	Heads Left on Last Cylinder of Sweep	Current head position determined by last sweep cycle -- not by controller-requested seek. On cylinder is inactive.
SEEK ERROR STATUS		
C6/46	Seek Timeout	Indicates the drive took longer than 100 milliseconds to reach on cylinder during a normal seek.
CB/4B	Off Track Seek Error	Indicates either the drive failed to stay on cylinder or cylinder pulses were detected during track-following.
CD/4D	Illegal Cylinder Address	Indicates controller issued too high a cylinder address (1380 for 850 MB or 1634 for 1153 and 1230 MB drives) during a normal seek.
CF/4F	Seek Error On Settle In	Indicates the drive could not settle on destination cylinder.

Continued

DRIVE STATUS CODES (CONTD)

Code	Title	Description
FIRST SEEK FAULT STATUS		
D4/54	First Seek Fault On Retract	Indicates the drive failed to complete the retract portion of the first seek.
D5/55	First Seek Fault On Load	Indicates the drive failed to load the heads.
D6/56	First Seek Fault On RTZ	Indicates the drive failed to complete the return to zero (RTZ) portion of the first seek.
D7/57	First Seek Fault On Calibrate	Indicates the drive did not complete the velocity calibration operation.
ERROR CONDITION STATUS		
D8/58	Speed Loss	Indicates spindle speed fell below 3564 r/min. The motor MPU inactivates the Speed OK code to the control MPU. The control MPU activates the Write Protect line, drops the Ready signal, and performs a retract operation.
D9/59	Motor Can't Start Due to Error	Indicates a problem in the motor control circuits.
DA/5A	Emergency Retract	Indicates the heads retracted to the landing zone due to a power loss (-Low Vcc active), or that a servo-controlled retract failed.

Continued

DRIVE STATUS CODES (CONTD)

Code	Title	Description
MOTOR AND SERVO MPU ERRORS		
E0/60	Motor MPU Failure	Indicates the Control MPU was unable to communicate with the Motor MPU.
E1/61	Servo MPU Failure	Indicates the Control MPU was unable to communicate with the Servo MPU.
I/O BOARD ERROR STATUS		
E2/62	I/O Board Status Failed	I/O MPU failed to transfer status successfully to the control MPU during a diagnostic test.
EE/6E	I/O Self-Test Failed	Failed I/O Read/Write Diagnostic self-test.

INTERFACE TESTING

This topic describes the unique self-tests and online diagnostic tests available with the IPI interface.

THE SELF-TEST AND INITIALIZATION SEQUENCE

The drive self-test and initialization sequence is shown on the flow chart below.

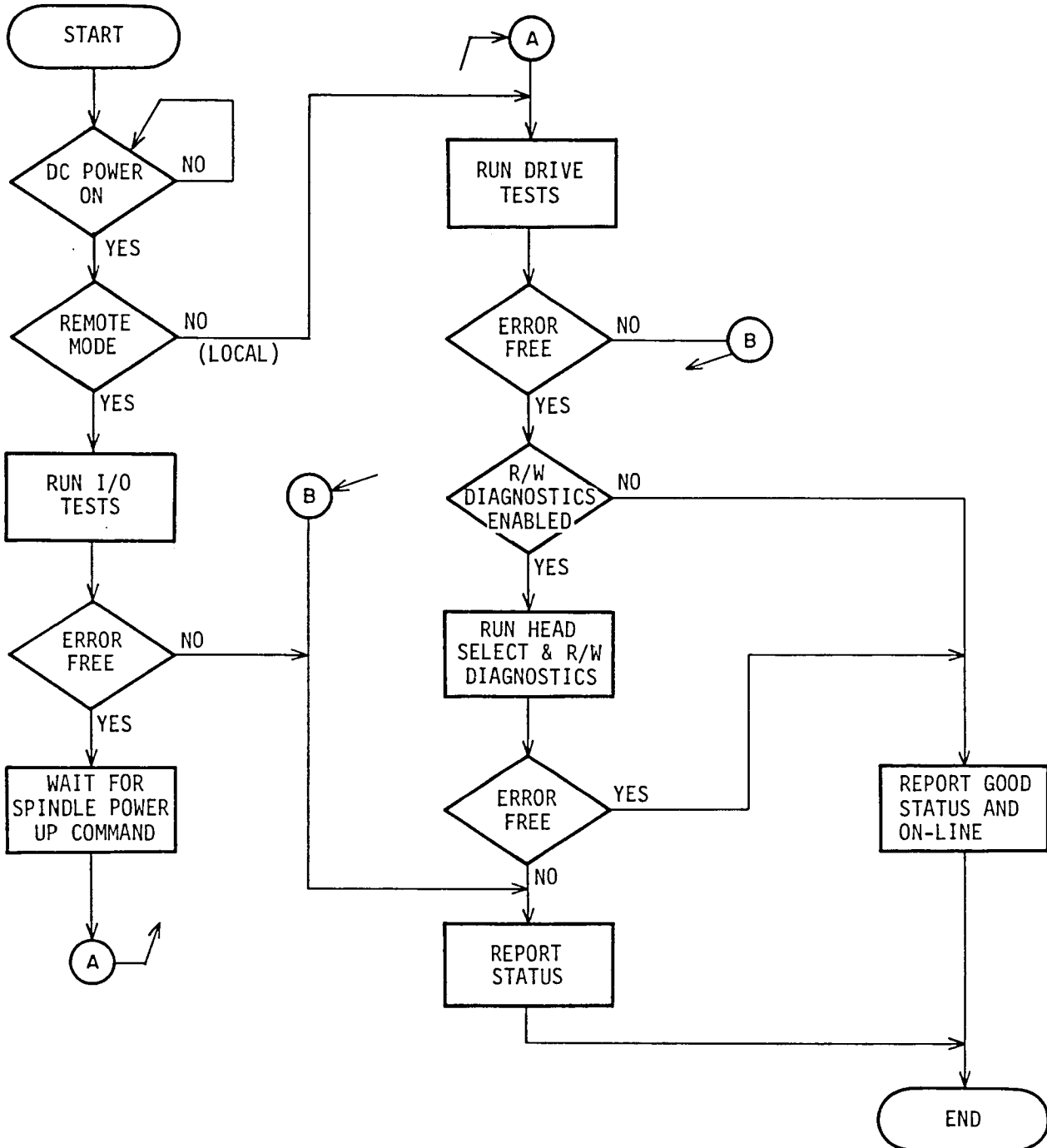

STARTING THE TESTS

The I/O MPU and drive control MPU self-test sequences start when dc power is applied or a Drive Selective Reset is received (see the flowchart below).

The I/O and drive circuits are tested first. The I/O tests include checks of the serializer/deserializer (SERDES) and I/O circuits, and an I/O MPU self-test. The drive self-test checks the control MPU. Testing stops and status is reported if an error is found.

The drive begins its start sequence if the I/O and drive self-tests run error-free. If these tests run error-free, the drive MPU runs a series of servo tests. The drive is capable of normal operation if these tests run error-free.

The controller can direct the running of write and read tests. The drive must be ready, not write protected, and there may be no faults present. If the drive is write protected it will run only the read portion of the tests.

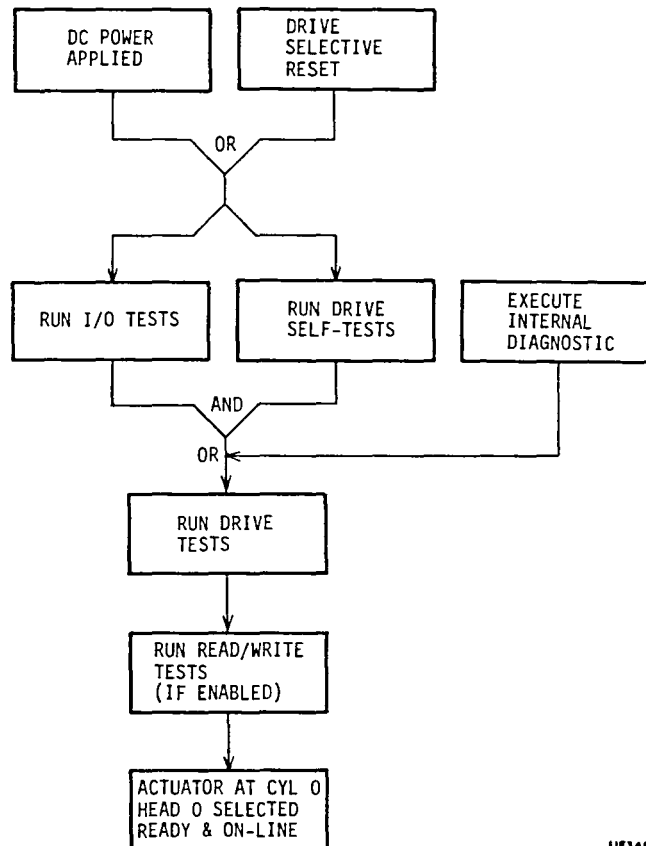

11F346A

If an error is detected in any test, testing stops and the appropriate error and status codes are reported. If all tests run error-free, the drive will be ready and the actuator will be at cylinder zero with head zero selected.

EXECUTE INTERNAL DIAGNOSTICS FUNCTION

Receipt of this function runs an access test, a head select test, and a read/write test.

The access test performs the following operations:

- Return to zero seek operation
- Single track seek
- Servo recalibrate
- Maximum seek
- Random seek

Successful completion of this test allows starting of the Head Select test provided the Disable Write/Read Diagnostic bit is not set. The Head Select and Write/Read tests can be disabled by issuing the Disable Read/Write Diagnostics Function Code.

The Head Select test performs a seek to the diagnostic cylinder, waits for on-cylinder, and then sequentially selects all heads on the cylinder. Successful completion of this test allows starting of the Write/Read test.

The write and read tests run if the drive is Ready, is not write protected, and no fault conditions exist. If the drive is write protected it will run only the access and read tests. The header is read and verified on the diagnostic cylinder. If no errors are found, data patterns are written on the diagnostic cylinder, after which they are read back and verified.

READ DRIVE SPECIFIC INFORMATION (BUS CONTROL 43)

The Read Drive Specific Information bus control transfers status information to the controller. This status information fits into two general categories:

- Native-controlled status -- generated by the drive MPU. Although the codes are numerically different, they report the information available via the maintenance panel.
- Interface-controlled status -- generated by the I/O MPU.

The response to the bus control has the parameters listed below and in the tables that follow.

- Native-Controlled Diagnostic Status Codes are presented in octets 02 - 11 and listed in the table on the next page. Each status code has an equivalent offline status code. The drive status codes (offline and online) were listed and defined earlier in this section.
- Native-Controlled Diagnostic FRU Codes are presented in octets 12 - 15.
- Native-Controlled Diagnostic Fault Codes are presented in octets 16 - 1D.
- Interface-Controlled Diagnostic Status Codes are presented in octets 1E - 1F
- Interface-Controlled Diagnostic FRU Codes are presented in octets 20 - 21.
- Interface-Controlled Diagnostic Fault Codes are presented in octets 22 - 23.

Native-Controlled Diagnostic Status Codes

Status Code	Status Description
80	Ready & On Cylinder
82	Motor Stopping
83	Motor Stopped
84	First Load/Calibrate
85	Sequence Delay
86	START Switch Pressed & Waiting for Power Sequence Signals
87	Starting Motor
88	Motor Up to Speed
89	I/O Self-Test Passed
8A	Drive in Sweep Segment
8B	Heads Left on Last Cylinder of Sweep
C6	Seek Timeout
CB	Off Track Seek Error
CD	Illegal Cylinder Address
CF	Seek Error on Settle In
D4	First Seek Fault on Retract
D5	First Seek Fault on Load
D6	First Seek Fault on RTZ
D7	First Seek Fault on Calibrate
D8	Speed Loss
D9	Motor Can't Start Due to Error
DA	Emergency Retract
E0	Motor MPU Failure
E1	Servo MPU Failure
E2	I/O Status Transfer Failed
EE	I/O Self-Test Failed

Native-Controlled Diagnostic FRU Codes

FRU Code	FRU Description
81	Control Board
82	Module
83	Power Supply
84	I/O Board
85	Control Board
86	Module

Native-Controlled Diagnostic Fault Codes

Fault Code	Fault Description
80	Good Status
81	Read and Write Fault
82	Read or Write and Not On Cylinder Fault
84	First Seek Fault
88	Write Fault
90	Write and Write Protected Fault
A0	Head Select Fault
C0	Voltage Fault

Interface-Controlled Diagnostic Status Codes

Status Code	Status Description
<u>Read/Write Tests</u>	
00	Good Status
01	Failed during seek to diagnostic cylinder
02	Failed during RTZ seek from diagnostic cylinder
03	Not defined
04	Not defined
05	Failed during head select test
06	Failed during read header test
07	Failed during write data test
08	Failed during read data test
09	Sync byte error during read header test
0A	Data error during read header test
0B	Sync byte error during read data test
0C	Data error during read data test
<u>Access Tests</u>	
13	Failed during servo test
14	Failed during random seek test
15	Failed during access RTZ test
<u>Read Drive Specific Tests</u>	
20	Failed during read up of diagnostic status/error code log test
21	Failed during read up of FRU log test
22	Failed during read up of display fault log test

Interface-Controlled Diagnostic FRU Codes

FRU Code	FRU Description
01	Control Board
02	Module
03	Power Supply
04	I/O Board
05	Control Board
06	Module

Interface-Controlled Diagnostic Fault Codes

Fault Code	Fault Description
00	Good Status
01	Read and Write Fault
02	Read or Write and Not On Cylinder Fault
04	First Seek Fault
08	Write Fault
10	Write and Write Protected Fault
20	Head Select Fault
40	Voltage Fault

